

4/3 Modular Directional valve NC

User and maintenance manual

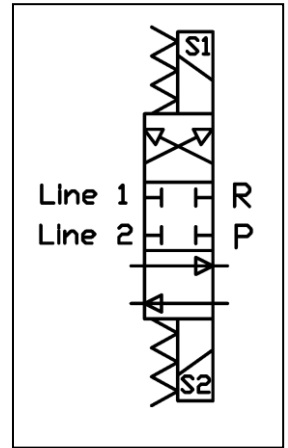

TABLE OF CONTENTS

1. INTRODUCTION
2. GENERAL DESCRIPTION
3. PRODUCT IDENTIFICATION
4. TECHNICAL CHARACTERISTICS
5. COMPONENTS
6. UNPACKING AND INSTALLING
7. OPERATING INSTRUCTIONS
8. TROUBLESHOOTING
9. MAINTENANCE PROCEDURE
10. DISPOSAL
11. ORDERING INFORMATION
12. DIMENSIONS
13. HANDLING AND TRANSPORTATION
14. OPERATING HAZARDS
15. PRECAUTIONS



Manual drawn up in accordance with
CE Directive 06/42

C2246IE WK 07/18

<http://www.dropsa.com>
Via Benedetto Croce, 1
Vimodrone, MILANO (IT)
t. +39 02 250791

Dropsa products can be purchased from Dropsa branches and authorized distributors, visit
www.dropsa.com/contact or contact us sales@dropsa.com

1. INTRODUCTION

This User and Maintenance Manual refer to Dropsa's " **4/3 Direction valve NC**" and contains important information. You can find additional copies and newer revisions of this document from our website <http://www.dropsa.com>.

Alternatively contact one of our Sales Offices.

This manual contains important information on health and safety issues the personnel. It is recommended to attentively read this manual and carefully keep it in good condition so that it is always available to personnel requiring to consult it.

2. GENERAL DESCRIPTION

The 4/3 Direction valve has been designed to control the Dual Line system (O2 System); it can operate with either oil or grease at a max pressure of 300 bar (4351 psi).

The main function of this 4/3 Direction valve is that each main line has to be pressurized and be relieved of pressure alternately. In rest position, the valve closes both lines.

3. PRODUCT IDENTIFICATION

Product identification label contains product serial number, input voltage and details of the operating parameters.

PRODUCT IDENTIFICATION TEST CERTIFICATE	
PART NUMBER	83550
VAR	
PACK QUANTITY	
DIRECTIONAL VALVE 4/3	
FLOW	400 cc/min
PRESSURE	Max 400 bar
GREASE	MAX NLGI 2
VOLT	24 V DC
WO: IT-	- 0002
Dropsa SpA, Milan Italy	
Year: 2014 MADE IN ITALY	
	
Scan for Info Scannen für Info Telechargez-info Info Prodotto 扫描产品信息 Сканер штрих-кода	
	
www.DropsA.com	

4. TECHNICAL CHARACTERISTICS

GENERAL CHARACTERISTICS	
Weight	6 Kg
ELECTRIC CHARACTERISTICS	
Voltage	24V DC
Power consumption	48W
Electromagnet Coil power absorption	2 A
Electromagnet Coil Protection degree	IP 65
HYDRAULIC CHARACTERISTICS	
Max flow rate	400 cc/min
Max working pressure	300 bar (4351 psi)
Outlet connection	G3/8" BSP
Working temperature	- 5 ÷ + 50 °C (23° ÷ +122° F)
Humidity	90 % rel. humidity
Lubricants	Max grease NLGI2
Storage temperature	-20 ÷ +65 °C (-4° ÷ +149° F)

N.b. The specifications refer to the temperature of use of +20°C (+68°F)

* If a different product is used, please contact Dropsa S.p.A. to ensure it is suitable for use



ATTENTION: Do not feed the product with different voltages from those specified on the plate.

4.1 Hydraulic diagram

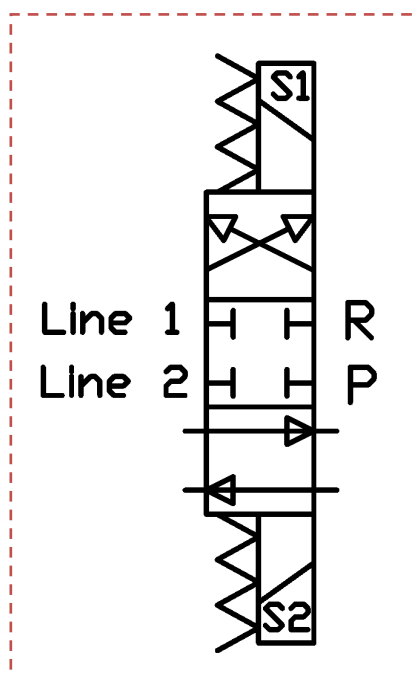

Energizing the S1 solenoid the line switches from 2 to 1.
 Energizing the S2 solenoid the line switches from 1 to 2.
 When the solenoid is un-energized the spool of valve moves to the centre and closes both two circuits.

5. COMPONENTS

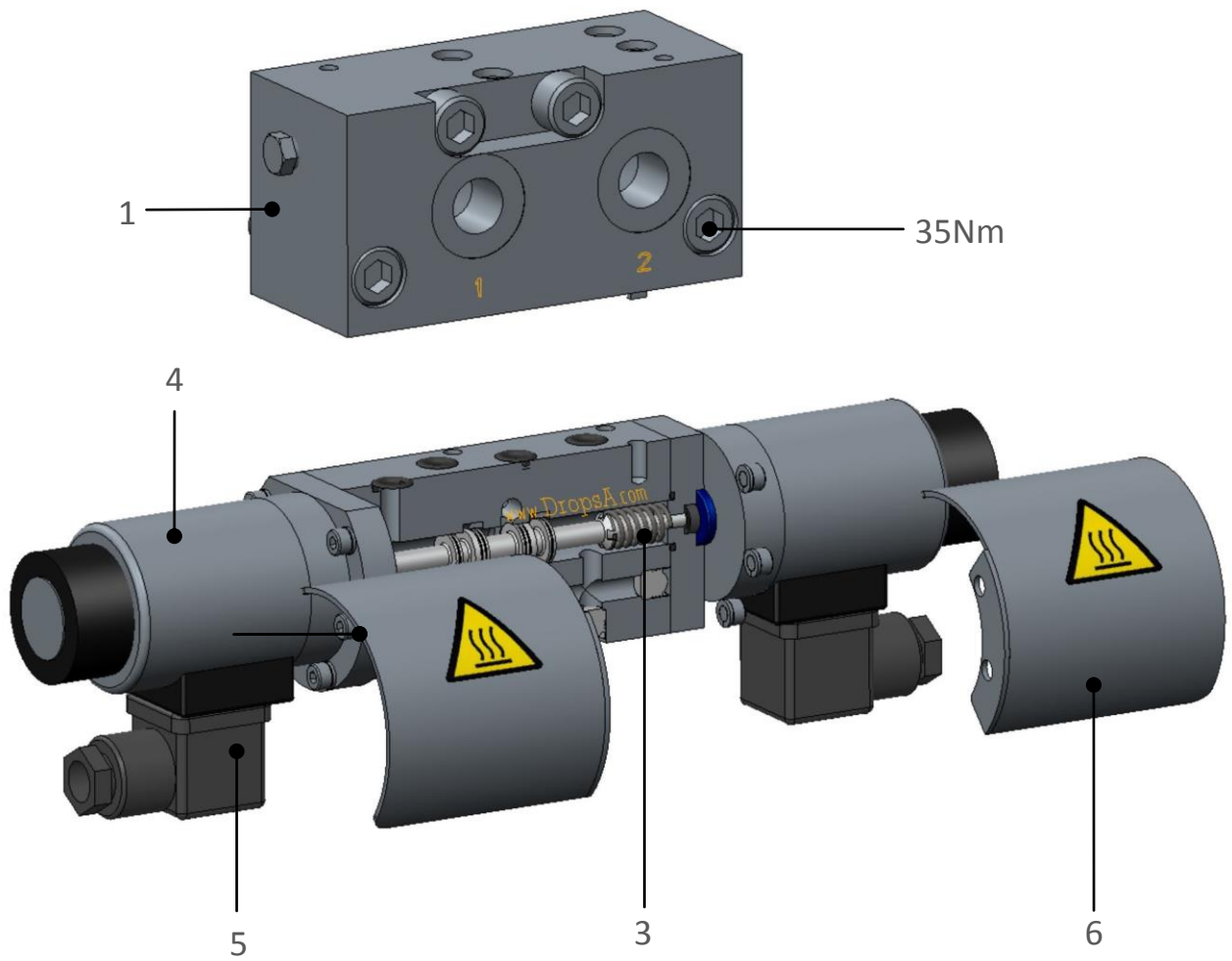

VALVE COMPONENTS	
1	Adapter plate for SUMO/MINISUMO pumps
2	Control piston
3	Return spring
4	Electromagnet coil
5	MPM Connector
6	Cover

6. UNPACKING AND INSTALLATION

6.1 UNPACKING

Once a suitable installation position has been identified, unpack the product and prepare for installation. It is important to inspect the product to ensure that there has been no damage during transportation or storage. The packaging material used does not require any special disposal procedures. You should refer to your regional requirements.

6.2 Installation

1. Fixing the valve on the pump using four M10 screws supplied, tightening with a torque of 35 Nm. Pay attention at the correct positioning of O-Rings.
2. Connect two outlet pipes to G3 /8" holes marked 1 and 2 on the adapter plate
3. Connect the wires to the connectors of the electromagnets. (See the pin connection in Fig.6.3)

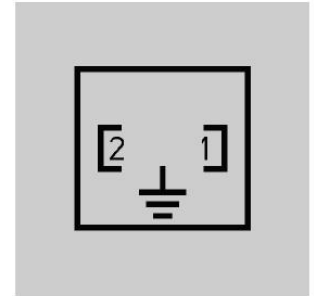

Fig.6.3

7. OPERATING INSTRUCTIONS

7.1 Start-up

Before using the product, a few preliminary checks must be performed:

- Check Modular directional valve integrity;
- Check that the valve is at working temperature and that the pipes are free of air pockets
- Check that the electrical connection has been carried out correctly (CEI 64/8, IEC 364);
- Ensure that the valve reverses properly
- Check that there is not lubricant leakage or air pressure loss;
- Check that the lock screws are properly screwed up;
- Use gloves and safety goggles, as stipulated in the safety chart for the lubricants;
- DO NOT use lubricants that may irritate the NBR gaskets; if in doubt, contact the Dropsa SpA technical office, which can provide you with a detailed chart of recommended oils;
- DO NOT ignore dangers to the health and maintain the regular hygiene standard.

8. PROBLEMS AND SOLUTIONS

TROUBLESHOOTING TABLE		
PROBLEM	POSSIBLE CAUSE	REMEDIAL ACTION
The modular valve doesn't invert	No power supply	Check the power supply line
	Piston jammed	Verify correct sliding of piston ⚠
		Possible replacement valve
	The modular valve has reached the maximum pressure level	Adjust the pressure to a maximum of 300 bar (4351 psi)
	Important lubricant leakage from one of the four connection pipes	Verify piping status and the connections to fittings. Replace worn out pipelines
Gasket broken	Replace ⚠	
The valve in rest position does not close the lines	Piston jammed	Verify correct sliding of piston ⚠
		Possible replacement valve
	Piston return springs broken	Replace ⚠
Valve leaks lubricant	Breaking of internal gaskets	Replace ⚠



ATTENTION: Operations by Dropsa specialized personnel (send the product to Dropsa).

9. MAINTENANCE PROCEDURE

The product does not need any special tool for operation and maintenance. When working with the pump it is recommended that personal health and safety equipment is used as is normal for any operation in an industrial or similar workplace.

The product has been designed and built as to require minimal maintenance and operate in different and challenging operating environment. It is recommend that the unit is inspected and kept clean to ensure long life and trouble free operation. It is important to check all tubing on the system to ensure that it is always tight and leak free.

ITEM	FREQUENCY	OPERATION
Integrity of tubing and system	After initial 500 hours. Every 1500 hours.	Check fittings and tubing secured. Verify components are correctly fixed to machine.



WARNING: Before carrying out any maintenance operation, ensure that power and hydraulic system are disconnected.

In any doubts and/or persistent problems, do not proceed to search by removing machine parts but contact our technical office

10. DISPOSAL

During maintenance or disposal of the product care should be taken to properly dispose of environmentally sensitive items such as oils or other lubricants. Refer to local regulations in force in your area.

When disposing of this unit, it is important to ensure that the identification label and all the other relative documents are also destroyed.

11. ORDERING INFORMATION

11.1. 4/3 Valve

Description	Part Number
4/3 Direction valve NC 24V DC	0083550

11.2. Optional

Description	Part Number
Pressure gauge Kit	3133910



11.2. Spare parts

Description	Part Number
24V DC electromagnet- 48W	3150016
MPM Connector	0039976
OR gasket valve/pump	3190500
Right pressure gauge	3292172
Left pressure gauge	3292171

12. DIMENSIONS

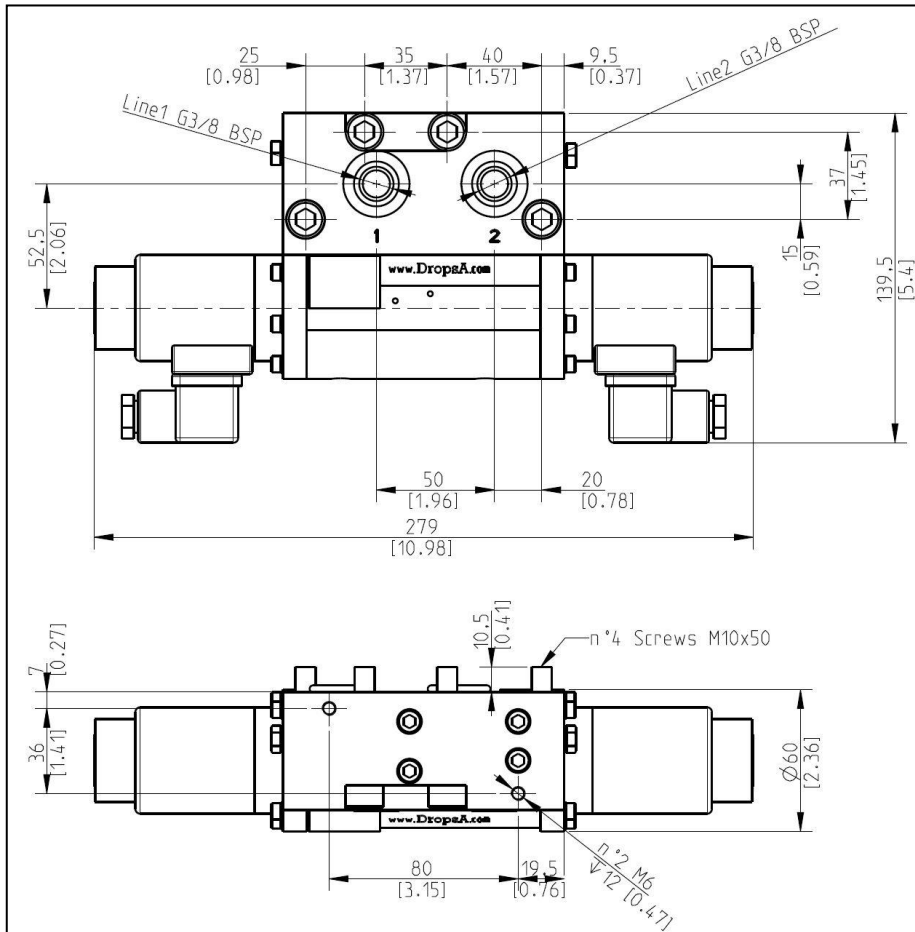

Dimensions in mm [in].

13. HANDLING AND TRANSPORT

Before shipping, the units are carefully packed inside cardboard boxes. When transporting and storing the equipment, pay attention to the direction indicated on the boxes themselves.

Upon receipt, check that the package has not been damaged and store the equipment in a dry location.

14. OPERATING HAZARDS



WARNING: It is necessary to carefully read about the instructions and the risks involved in the use of lubrication machines. The operator must know the machine functioning through the User and Maintenance Manual.

Power supply

Do not carry out any work on the product before disconnecting it from the electrical power supply and making sure that no one can reconnect it during the operation. All the installed equipment (electric and electronic), tanks and basic structures must be connected to the ground line.

Flammability

The lubricant generally used in lubrication systems is not normally flammable. However, it is advised to avoid contact with extremely hot substances or naked flames.

Pressure

Before each operation, make sure there is no residual pressure in every branch of the lubrication circuit that could cause oil to spray when disassembling fittings or components.

Noise

Under normal operating conditions, noise emission does not exceed 70 dB "A".

Extreme temperatures

Before carrying out any work on the machine, ensure that the coils are cold.



ATTENTION: The external parts may be hot during operation

14.1 LUBRICANTS



NOTE: The pump is designed to operate with maximum NLGI 2 grade lubricants.

Use lubricants compatible with NBR gasket

The residual lubricant used for assembly and testing is NLGI 2 grade.

A comparison table is provided between the classification of NLGI lubricants (National Lubricating Grease Institute) and the ASTM classification (American Society for Testing and Materials) for greases for the values that concern the product.

GREASES	
NLGI	ASTM
00	400 – 430
0	355 – 385
1	310 – 340
2	265 – 295

For further information about the technical specifications and the safety measures to adopt, refer to the product safety sheet (Directive 93/112/EEC) relative to the type of lubricant selected and supplied by the manufacturer.

15. PRECAUTION

Compliance with the essential safety requirements and the provisions specified in the machine directive was checked by filling out prepared check lists that are contained in the *technical file*.

Three types of lists were used:

- Risk assessment (Appendix A of EN 1050).
- Compliance with the essential safety requirements (Machine Directive)
- Electrical safety requirements (EN 60204-1).

The following is a list of dangers which have not been fully eliminated but which are considered acceptable:

- During installation there may be small low pressure oil seepage from the pump. Always use appropriate protective clothing, gloves and take all necessary safety precautions.
- Contact with lubricant during maintenance → As per previous point, correct precautions must be taken to protect from contact with lubricant.
- Electric shock. → All electrical connections must be carried out by a qualified electrician who has studied the connection to ensure no electrical danger
- Unsuitable Lubricant. → Lubricant characteristics are indicated in this user manual. In any case contact a Dropsa Sales and Support engineer (**if in any doubts, contact the Technical Department Dropsa SpA**).
- Contact with hot surfaces. → During normal operation, the solenoid surface may reach high temperatures; for this reason, protection has been devised to avoid direct contact and a danger notice has been provided.

FLUIDS EXPLICITLY NOT ALLOWED	
Fluid	Dangers
Lubricants with abrasive additives	Wear of the components inside the valve
Lubricants with silicone based additives	Pump seizure
Petrol – solvents – inflammable liquids	Fire – explosion – damage to the gaskets
Corrosive products	valve corrosion - damage to people
Water	Valve oxidation
Food substances	They would be contaminated