

## Use and maintenance manual

Original instructions

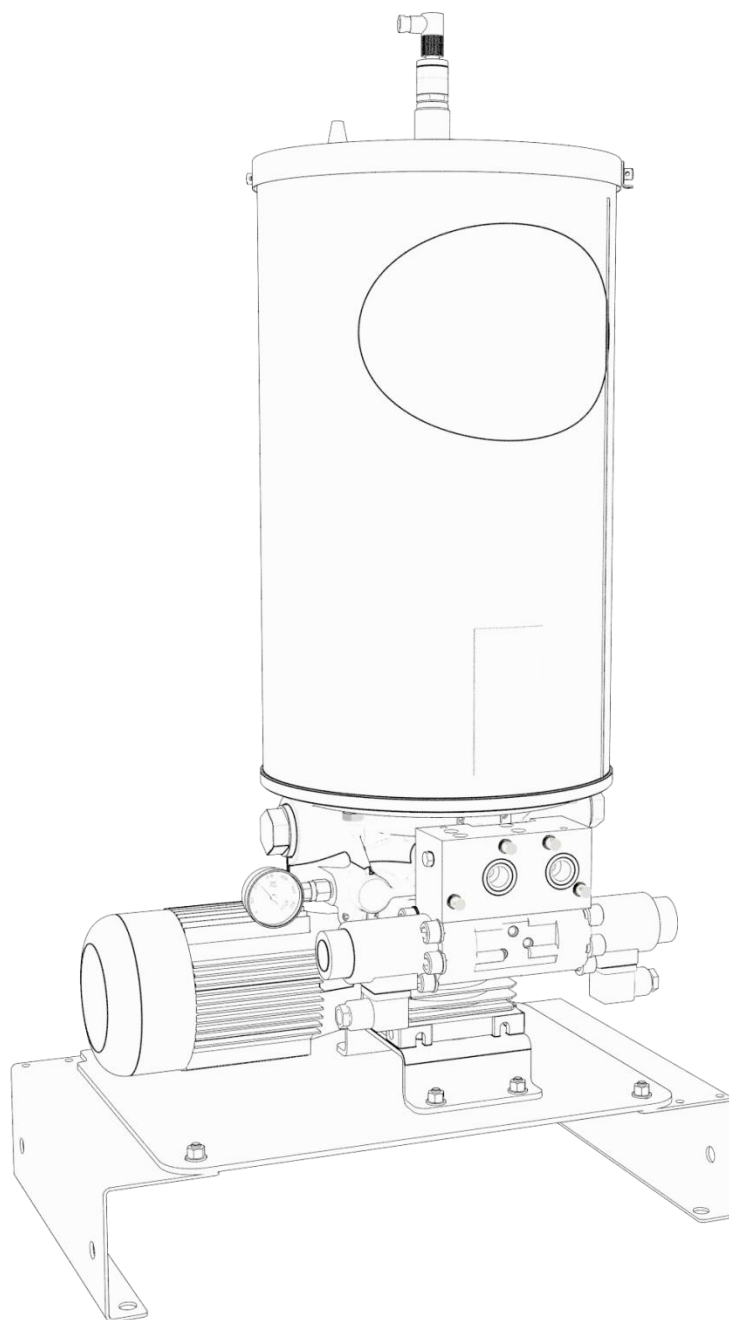

Manual drafted in compliance  
with directive 2006/42

C2280IE - WK 40/20

---

[www.dropsa.com](http://www.dropsa.com)

DropsA products can be purchased at DropsA branches and authorised distributors,  
go to [www.dropsa.com/contact](http://www.dropsa.com/contact) or write to [sales@dropsa.com](mailto:sales@dropsa.com)

## Index

1. INTRODUCTION.....	2	5. Operating instructions .....	15
1.1 GENERAL INFORMATION.....	2	5.1 Preliminary procedures.....	15
1.2 MANUFACTURER DATA.....	2	5.1.1 Filling the reservoir with grease.....	15
1.3 Identification label .....	2	5.2 .....	15
1.4 How to use .....	2	5.3 Starting the pump .....	16
1.5 Personnel qualification .....	3	5.4 Stopping the pump .....	16
1.6 Personal protective equipment .....	3	6. Adjustments.....	17
2. Safety.....	4	6.1 Adjustment/calibration of the level probe .....	17
2.1 General warnings .....	4	6.1.1 Calibration of the laser Level probe 0295131, 24Vdc Out NO and NC (1 threshold).....	17
2.2 Residual risks.....	4	6.1.2 Laser probe calibration thresholds 0295130, 24Vdc Out 4~20mA/2 NO (4 thresholds) .....	18
2.3 Pictograms.....	5	6.1.3 REED floating switch connection 0295150/0295160.....	18
3. Machine description.....	6	7. Maintenance.....	19
3.1 Intended use and prohibited use .....	6	7.1 General warnings .....	19
3.1.1 Intended use .....	6	7.2 Maintenance operations table.....	20
3.2 Sound emissions.....	7	7.2.1 Piping joints check .....	20
3.3 Technical specifications.....	8	7.2.2 General cleaning of the pump .....	20
3.4 Dimensions.....	9	7.2.4 Replacing pumping elements.....	21
3.5 Standard pump components.. <b>Errore. Il segnalibro non è definito.</b>		8. Troubleshooting.....	22
3.5.1 Inverters .....	10	8.1 Problems, causes and solutions .....	22
3.5.2 Fixed fixed flow rate pump elements .....	10	9. Ordering information.....	23
3.5.3 Minimum and maximum level indicators for grease/oil .....	11	9.1 Standard versions .....	23
3.5.3.1 Laser for grease minimum level (optional) ...	11	9.2 Optional equipment.....	24
3.5.3.2 Floating switch minimum/maximum level sensor for oil .....	11	9.3 Spare parts .....	24
3.5.3.3 Floating switch visual maximum level for grease/oil .....	11	10. Additional information.....	25
3.5.4 Grease and oil stirring paddle (standard execution) .....	11	10.1 Waste disposal .....	25
3.6 Electrical equipment .....	11	10.2 Toxic-harmful waste.....	25
4. Installation .....	12	10.2.1 Provisional storage.....	25
4.1 Receipt and checking the content.....	12	10.2.2 Characteristics of the containers .....	25
4.2 Packaging .....	12	10.2.3 Registration obligations .....	26
4.3 Transport and handling.....	12	10.3 Scrapping the machine .....	26
4.4 Storage .....	13	10.4 Dismantling of the electronic components (WEEE directive) .....	26
4.5 Environmental conditions .....	13	11 Attachments .....	27
4.6 Installation .....	13	11.1 Hydraulic diagrams .....	27
4.7 Electrical connection .....	14		

## 1. INTRODUCTION

### 1.1 GENERAL INFORMATION

With this manual, we wish to provide you with all the important information for the safety of installation, operation and maintenance personnel and for the decommissioning of the MINISUMO II pump.

The most recent version can be obtained by requesting it from the Sales Technical Office or online at <http://www.dropsa.com>.

This manual, drafted originally in the ITALIAN language, constitutes an integral part of the pump and must be carefully kept for the entire life of the same.

In the event that the pump is sold, rented or lent for use, it must be delivered to the new user together with the EC Conformity Declaration.

Carrying out any operation on the pump without first having carefully read and comprehended all the instructions contained in this manual is prohibited.

The images contained in this manual are purely illustrative and are not binding for the Manufacturer who reserves the right to make changes to components and/or parts for improvement or other reasons without updating this manual if these changes have not altered the operation and safety of the pump.

### 1.2 MANUFACTURER DATA

DropsA S.p.A.  
Via Benedetto Croce, 1  
20090 – Vimodrone (MI) – ITALY  
Ph. +39 02 250 791  
Fx. +39 02 250 79 767  
E-mail: [sales@dropsa.it](mailto:sales@dropsa.it)  
Web: <http://www.dropsa.com>

### 1.3 Identification label

A yellow is located on the front part of the pump reservoir that indicates the product code and the basic characteristics.

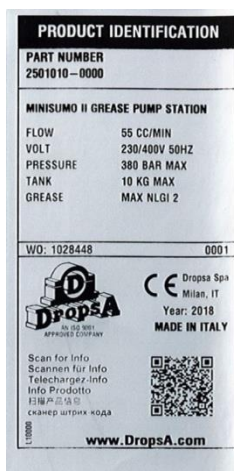

#### ATTENTION

*Removing or tampering with the identification label is strictly prohibited.*

### 1.4 How to use

For a better understanding of the information provided in this manual, the warnings or instructions that are considered to be critical or dangerous are highlighted with the following symbols:



#### DANGER

*For instructions that, if not followed, may cause danger.*



#### ATTENTION

*For instructions which, if not followed, may cause damage to the pump.*

## 1.5 Personnel qualification

To ensure that all the operations carried out on the pump take place in safe conditions, the operators in charge must possess the qualifications and prerequisites required to carry out the relative operations.

The operators are classified as follows:



### FIRST LEVEL OPERATOR:

unqualified personnel, in other words, without specific skills, capable of carrying out only simple tasks.



### MECHANICAL MAINTENANCE SPECIALIST:

qualified technicians that are capable of performing adjustments, maintenance and repair operations upon the machine's mechanical components. This person is not qualified to work on live electrical systems.



### ELECTRICAL MAINTENANCE SPECIALIST:

qualified technician responsible for all electrical operations. This person is capable of operating on the machinery even with live electrical cabinets and junction boxes.

## 1.6 Personal protective equipment

This operating manual presumes that the pump has been installed in a workplace where all of the compulsory safety requirements are observed. Specifically, personnel must be provided with personal protection equipment in relation to the operations that they must fulfil.



### **PROTECTIVE GLOVES**

These must be suitable for the hand of the operator who must wear them and they must be long enough to cover the operator's elasticised garment at the wrist. They must guarantee a secure and quick grip, as well as high resistance to the product being handled. They must also guarantee protection and comfort against low and high temperatures and good absorption of perspiration.

Protective gloves must be used in the event of work and maintenance operations on the pump.



### **EYE PROTECTION**

These must be of suitable dimensions for the operator's face, they must provide maximum visual field and comfort and be suitable for prolonged use. They must provide maximum safety against possible infiltrations and they must protect from drops and sprays.

Eye protection must be used each time work or cleaning instruments are used that imply the projection of solid particles, even very small ones.



### **PROTECTIVE FOOTWEAR**

The footwear must have an anatomic, anti-stress insole, allow proper breathability of the foot for the comfort of the foot and the upper part must be impenetrable to contact with the product being used. They must completely cover the ankle, overlapping with the trousers and they must be the type that allow rapid removal of the foot in the event that this should be necessary.

They must have a steel toe for protection against impact and crushing.

Protective footwear must be used throughout the entire period that work and maintenance is carried out on the pump.

## 2. Safety

### 2.1 General warnings

Before carrying out any operation on the pump, it is important to read this manual. Always observe the safety regulations of the nation in which the pump is installed and the need to use specialised personnel in the various operations of maintenance, operation, installation, etc. required during the life of the pump.

The main rules of conduct to be observed to work at a good safety level are the following:

- The operations of installation, operation, maintenance, etc. must always be carried out by qualified and trained personnel.
- It is good practice to always wear the foreseen personal protection equipment without exception.
- Always carry out all of the cleaning, adjustment and maintenance operations ensuring that the power supplies are disconnected.
- Never direct jets of water toward the electrical parts, even if they are protected by housings.
- Never smoke during operation or maintenance, especially in the event that flammable solvents or materials are used.
- Do not damage the labels, signs and pictograms applied to the pump. In the event that they are damaged inadvertently, replace them immediately with identical ones.
- Checking the chemical compatibility of the pump construction materials with the fluid that you intend to pump. An incorrect choice could cause, in addition to damage to the pumps and the lines, serious risk to personnel (leaking of products that are irritants and harmful to the health) and to the environment.
- Never exceed the maximum permitted operating pressure value for the pump and the components connected to it. If in doubt, see the data on the machine's label.
- Use only original spare parts.
- If you must replace components with others, ensure that they are suitable to function at the pump's maximum operating pressure.

DropsA S.p.A. will not be held liable for damage to people or objects stemming from improper use of the pump, tampering with its safety devices or failing to observe occupational health and safety regulations.



#### ATTENTION

*Never try to stop or deviate any leaks with your hands or other parts of the body.*



#### ATTENTION

*The warnings on risks using a lubricant pump implies must be carefully read. The user must be familiar with operation through the Operation and Maintenance Manual.*

### 2.2 Residual risks



#### DANGER

*The pump was designed in such a way so as to reduce residual risk for personnel to a minimum. Nevertheless, we urge caution and attention in carrying out maintenance operations. Unfortunately, the familiarity achieved through frequent contact with the pump often leads to forgetting or underestimating any risks.*

The hazards that have not been entirely eliminated, but that have been deemed acceptable, are listed below:

#### Contact with lubricant during maintenance or filling the reservoir

During the maintenance phase, low pressure spurts of lubricant are possible. (For this reason, maintenance operations must be carried out using suitable PPE, in accordance with the prevailing regulations).

Protection from direct or indirect contact with the lubricant must be ensured by the machine user.

**Use of unsuitable lubricant.**

The characteristics of the lubricant are indicated both on the pump and in this Operation and maintenance manual (in the event of any doubt, contact the Dropsa S.p.A. Technical Office):

**Electrical current**

No operations must be carried out on the machine before disconnecting it from the electrical power supply and ascertaining that no-one can reconnect it during the operation. All of the installed equipment (electrical and electronic), reservoirs and base structures must be connected to the ground line.

**Electrocution**

This can occur only in the event of serious negligence by the user who, however, is qualified.

**Flammability**

The lubricant used in the lubrication circuits is a fluid that is not normally flammable. In any case, all possible measures must be taken to prevent it coming into contact with very hot parts or naked flames.

**Pressure**

Before any operation, check for the absence of any residual pressure in all branches of the lubricant circuit, that could cause spurts of oil or grease in the event that fittings or components are disassembled. After long periods of inactivity, check the seal on all the parts subject to pressure. Do not subject the fittings, pipes and the parts under pressure to violent impact. A damaged hose or fitting is DANGEROUS. Replace it.

We recommend using only original spare parts.

## 2.3 Pictograms

Some pictograms are applied on the pump with warning and safety symbols for the operators. Carefully read and familiarise yourself with the symbols and their message before using the pump.

**ELECTRICAL HAZARD**

*You are close to electrical connections (protected) but accidental contact with them may cause electrocution and even death.*

**LASER RADIATION HAZARD**

Dropsa S.p.A. will not be liable for damage to people or things due to the failure to observe the regulations indicated by the pictograms or their imperfect preservation.

### 3. Machine description

The MINISUMO II range of lubrication pumps are particularly suited for dual-line and progressive systems and can adapt to many needs without mechanical modifications, even after installation. In fact, by choosing a set of components that are perfectly compatible with one another and easy to assemble, you can vary the pressure, the quantity of lubricant distributed, the type of lubricant or the type of distribution.

This construction technique is based essentially on the following modules:

- Motor
- Pump body
- Two pumping elements
- Reservoir
- Valves and output assemblies (inverter, pressure adjustment valve, etc.).

The bearing structure is the same for any version. The dual pumping element constitutes the essential module.

The pumping element normally has only one outlet, but the version with separate outlets can be requested.

Two types of grease and oil reservoirs with different volumes (10 or 30 kg~22 or 66 lbs) can be arranged on the pump body with stirring paddle and electric level indicator.

The MINISUMO II electric pump is fully protected against the external environment and can operate without difficulty even in the most severe environmental conditions.

#### 3.1 Intended use and prohibited use

##### 3.1.1 Intended use

The MINISUMO II pump is the ideal electric DropsA pump for use with single and dual line systems.

Lubrication systems engineered with the Dual Line System are generally used on large scale machinery and in harsh operating conditions to lubricate multiple points on large machines.

**NOTE: The pump is designed to work with maximum NLGI 2 grade lubricants.**

**Use NBR gasket compatible lubricants.**

**Any residual lubricant inside that was used for assembly and testing is NLGI 2 grease.**



A table is shown that compares the NLGI (National Lubricating Grease Institute) and ASTM (American Society for Testing and Materials) categories for greases, limitedly to the values that involve the pump.

For further information on the technical characteristics and the safety measures to adopt, see the Product Safety Data Sheet (Directive 93/112/EEC) related to the type of lubricant selected and supplied by the manufacturer.

GREASES	
NLGI	ASTM
000	445 – 475
00	400 – 430
0	355 – 385
1	310 – 340
2	265 – 295

## Prohibited Use



***Any use other than that for which the pump was built is an abnormal condition and therefore may cause damage to the pump itself and constitute grave danger for the operator.***

A series of operations relative to improper use of the pump which are prohibited under any circumstances are listed below.

- Use the pump only in industrial installations. Different use of the machine is prohibited;
- Do not use the pump in conditions other than those indicated in this operation and maintenance manual;
- Do not use the pump in an explosive or aggressive atmosphere. or in an atmosphere. with a high concentration of airborne dust or oily substances;
- Do not make changes, transformations, carry out repair or maintenance operations on the pump of your own initiative. Maintenance work may be carried out only in compliance with the indications in this manual.
- Do not use non-original replacement parts or parts not foreseen by the Manufacturer;
- Do not use the pump to pump substances other than those permitted. Use of prohibited materials may damage the pump, deteriorate its performance or reduce its useful life;
- Do not expose the pump to rain, steam, excessive humidity or direct sunlight;
- Do not install the pump in locations subject to flooding;
- Do not place or store near flammable or combustible materials or substances;
- Do not open the oil filler or drainage caps during operation of the pump.

PROHIBITED FLUIDS	
FLUIDS	HAZARDS
Lubricants with abrasive additives	Wear of pump internal components
Lubricants with silicon additives	Seizing of the pump
Petrol – solvents – flammable liquids	Fire – explosion – damage to the gaskets
Corrosive products	Corrosion of the pump – damage to personnel
Water	Oxidation of the pump
Food substances	Contamination of the same

**For more detailed information on the compatibility of the product with particular fluids, contact the DropsA S.p.A. Technical Office.**



### ATTENTION

***Using the pump submerged in fluids or in a particularly aggressive or explosive/flammable environment is prohibited unless it has been prepared ahead of time by the supplier for this purpose.***



### ATTENTION

***DO NOT use lubricants that are aggressive to NBR gaskets. If you are unsure, contact the DropsA SpA technical office for a detailed list of recommended oils.***

## 3.2 Sound emissions

In normal operating conditions, the noise emission does not exceed the value of 70 dB “A” at a distance of 1 metre (39.3 inches) from the pump.



### 3.3 Technical specifications

GENERAL SPECIFICATIONS	
Empty weight (10 Kg reservoir)	40 Kg - 88 lbs
Empty weight (30 Kg reservoir)	45 Kg - 99 lbs
Empty weight (100 Kg reservoir)	60 Kg - 132 lbs
ELECTRICAL SPECIFICATIONS	
Motor power supply	230-400V - ±5% 50Hz 280-480V - ±5% 60Hz 24V cc Insulation class F
Motor power rating	0.37 Kw
Motor protection degree	IP 54
Minimum level	Laser (grease) – Float (oil)
Maximum level	Float (grease/oil)
HYDRAULIC SPECIFICATIONS	
Pumping system	Piston
Flow rate (2 pumping elements)	110 cc/min
Maximum operating pressures	380 bar (5511 psi) - <sup>(1)</sup> 300 bar (4351 psi)
Outlet connection	G3/8" BSP
Reservoir capacity	10-30-100 Kg (22-66-220 lbs)
Filling filter	Filtering grade 300 μ
By-pass valve	Adjustable 0~380 bar (0~5511 psi) – precalibrated 300 bar (4350 psi) - <sup>(1)</sup> 250 bar (3625 psi)
Operating temperature	- 10 ÷ + 50 °C (+14~122F)
Operating humidity	90% R.H.
Permitted lubricants <sup>(1)</sup>	Mineral oil lubricant, min. 32 cSt; max. grease NLGI2
Storage temperature	-40 ÷ +65 °C (-40~149F)
Continuous sound pressure level	< 70 dB(A)

Note: The specifications refer to an operating temperature of + 20°C (+ 68°F)

<sup>(1)</sup> With 24V cc motor

<sup>(2)</sup> If a different product is used, you must ask DropsA S.p.A. if it is suitable for use

### 3.4 Dimensions

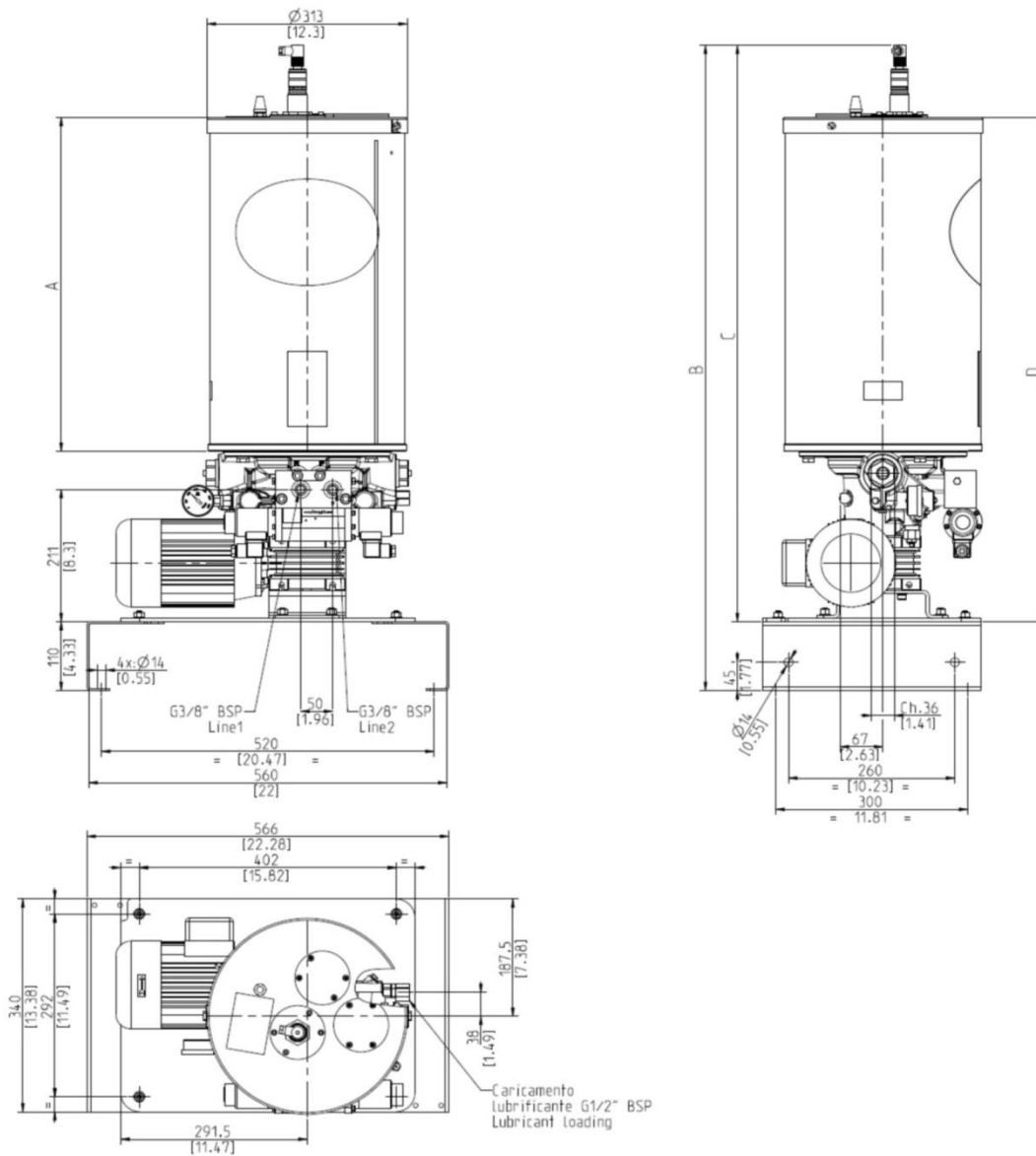

	10 Kg	30 Kg	100 Kg
<b>A</b>	344 [13.5]	533	983
<b>B</b>	841 [33.1]	1030	1480
<b>C</b>	731 [27.7]	920	1370
<b>D</b>	616 [24.2]	805	1255

### 3.5 Standard pump components

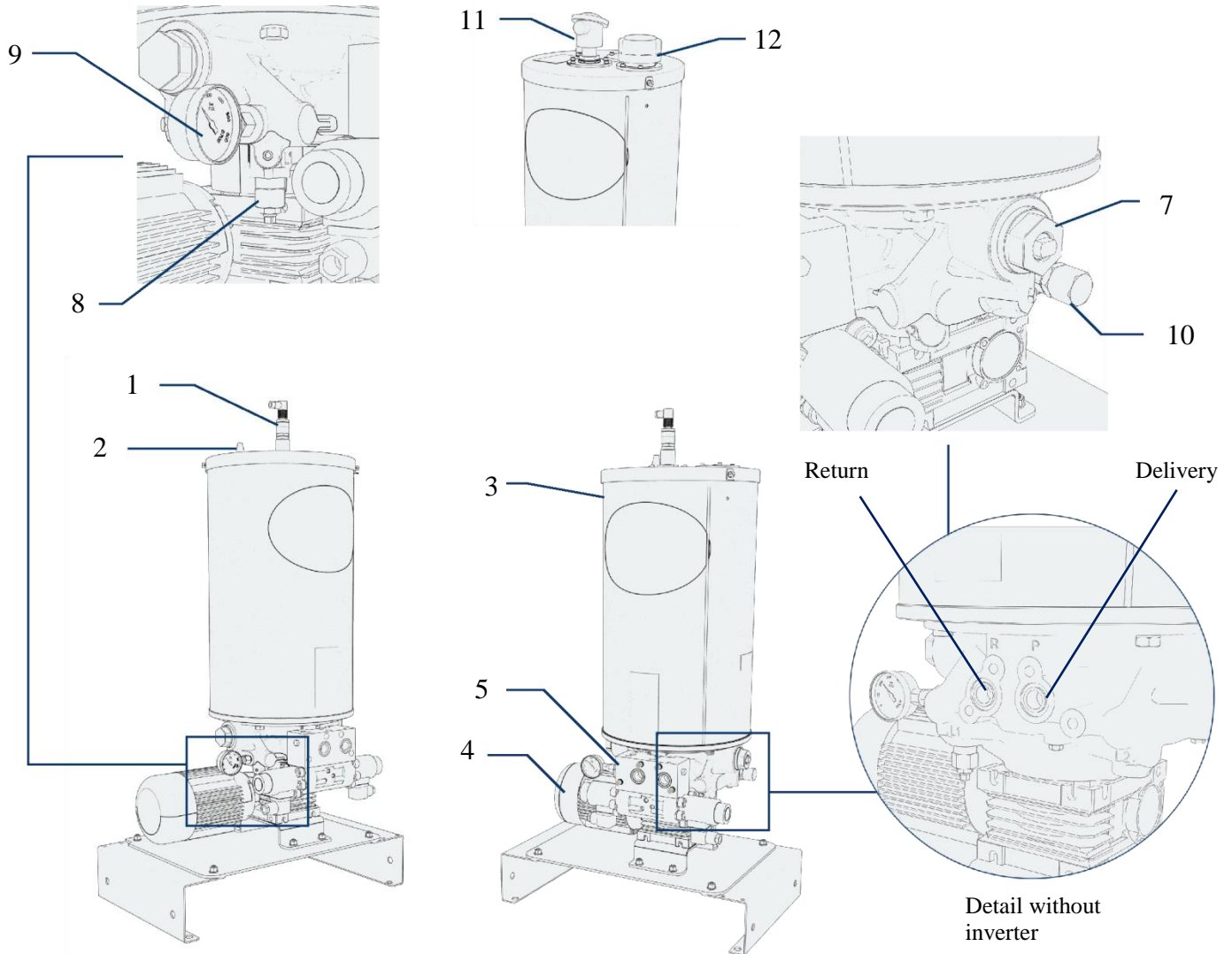

STANDARD PUMP COMPONENTS			
1	Laser minimum level	7	Pumping system
2	Maximum level	8	Bypass
3	Reservoir	9	Pressure gauge
4	Ratio motor	10	Filling (for grease pump)
5	Delivery line 1	11	Reservoir minimum level (for oil pump)
6	Delivery line 2	12	Lubricant filler cap (for oil pump)

#### 3.5.1 Inverters

For the inverter technical specifications and the methods of use, see the specific product manuals attached to the pump.

#### 3.5.2 Fixed flow rate pump elements

The pump is configured with one or two fixed flow rate pumping elements (110 cm<sup>3</sup>/ min for each pumping element).

The seal between piston and pumping body is a dry type since it has no gasket in between.

The pumping element check valve is the tapered seal type. This solution allows an outstanding seal of the system to be guaranteed at high operating pressures (max pressure of 400 bar – 5800 psi).

The pumping elements are mounted on the pump body without the need to disconnect the piping of the line with a threaded connection, which makes it easy to assemble/disassemble.

### 3.5.3 Minimum and maximum level indicators for grease/oil

#### 3.5.3.1 Laser for grease minimum level (optional)

The minimum level is achieved by a laser probe. The probe is normally closed when there is grease. When the minimum level is reached, the probe signals the lack of lubricant.

For connections and setting see Par. 6.1.1 and 6.1.2.

#### 3.5.3.2 Floating switch minimum/maximum level sensor for oil

A dipstick probe with dual floating switch mounted on the pump cover allows the minimum oil level (reserve) and the maximum level (that allows the interruption of automatic reservoir filling) to be read.

For connections, see Par. 6.1.3.

#### 3.5.3.3 Floating switch visual maximum level for grease/oil

The filling phase of the lubricant in the reservoir is carried out by the operator with an appropriate pump.

Once the maximum level of lubricant is reached, the rod that indicates that the reservoir is full intervenes.

### 3.5.4 Grease and oil stirring paddle (standard execution)

Two reservoirs have been provided with capacity of 10, 30 and 100 kg. (22-66 – 220 lbs).

As standard, the reservoirs have the stirring paddle and the scraper that do not need to be disassembled in the event of disassembly and replacement of the same. As standard equipment, under the stirring paddle there is an electrogalvanized steel mesh with 0.5 mm (0.02 in.) holes. There pump is thereby protected from any foreign objects that could be inadvertently present during the reservoir filling phase.

## 3.6 Electrical equipment

“DROPSA” electrical equipment is designed for the purpose of providing a system complete with all the controls needed for operation of centralized lubrication systems that is automatic and controlled by safety signals. The primary supply voltage is 400 Vac and 50 Hz. Other voltages are available on request. For more information on the available version, contact the DropsA sales engineers.

Type of probe	Type of inverter*	Supply voltage V **	Code Electrical equipment VIP5 PRO	Code Electrical equipment VIP5 PLUS	Code Electrical equipment with PLC
LASER PROBE 24Vdc (standard) Out NO and NC (1 threshold) or Floating switch	Electromagnetic Valve 4/2 or hydraulic	24 VDC	1639211	1639210	1637008
	Electro-pneumatic Valve 4/2 or hydraulic	24 VDC			1637011
LASER PROBE 24Vdc Out 4~20mA/2 NO (4 thresholds)	Electromagnetic Valve 4/2 or hydraulic	24 VDC	1639211	1639210	1637001
	Electro-pneumatic Valve 4/2 or hydraulic	24 VDC			1637005

\*For control equipment with 4/3 inverter, contact the DropsA technical sales office.

\*\*For other primary power supply and inverter voltages, contact the DropsA technical sales office.

## 4. Installation

### 4.1 Receipt and checking the content

Upon receiving the pump, you must ensure that the packaging is intact or whether there are clear signs of damage due to transport or storage conditions. If everything is intact, proceed with unpacking and checking the pump.

Otherwise, if damage to the packaging is found, the transport agent and the manufacturer must be notified immediately.

The material received must always be checked to ensure that it corresponds to what is indicated on the accompanying document.

The packaging must be opened using every precaution in order to prevent damage to people and the contents of the package itself.

### 4.2 Packaging

The pump is packaged in the following way:

- Secured on a metallic pallet with lateral packaging and cover in wood.

The wood can be reused or recycled in compliance with the prevailing laws in the country of installation of the pump. Other materials such as cardboard, plastic or the protective film must be disposed of in accordance with the relevant prevailing local regulations.

Do not burn or dispose of the package contents into the environment.

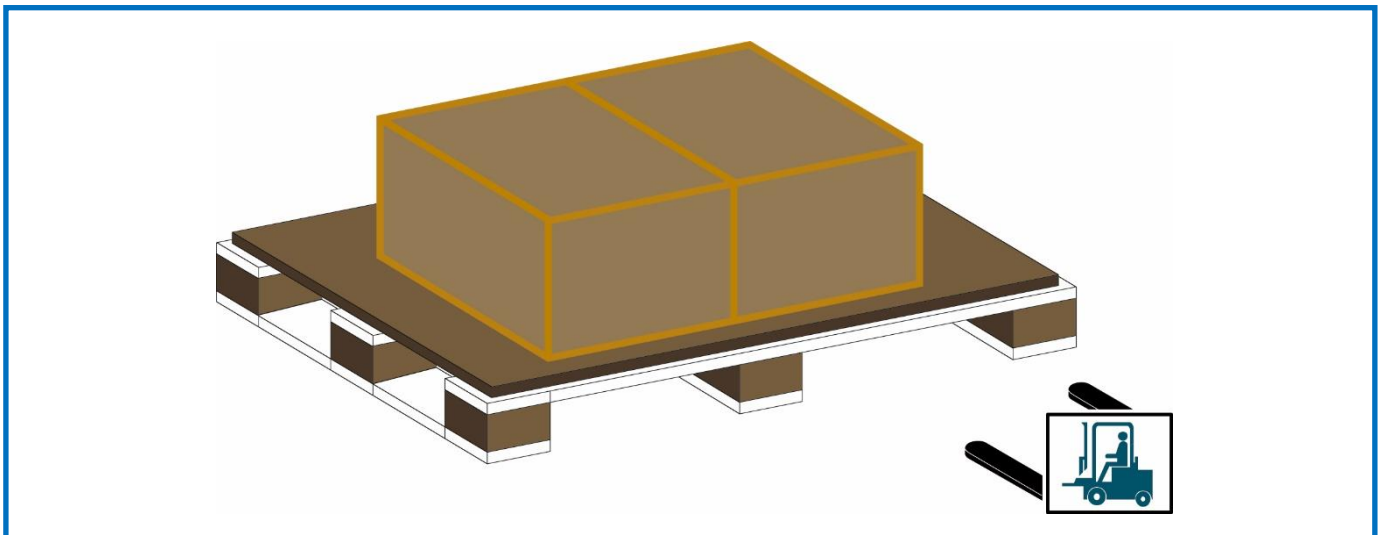

### 4.3 Transport and handling



#### **DANGER**

*The transportation, lifting and handling operations must be carried out by expert and qualified personnel.*

The pump can be lifted and handled with forklifts or pallet jacks suitable for the weight of the same, indicated on the technical data table and in any case on the identification label. Manual handling and transport is permitted only in compliance with the relevant prevailing local regulations.

**Lift the equipment bearing in mind the direction indicated on the box.**



**The components of the machine can withstand temperatures during storage from -40°C to + 65°C (-40°F~149°F). However, in order to prevent damage, start-up must take place when the machine has reached a temperature of -10°C (+14°F).**



#### **ATTENTION**

*For transport, we recommend preparing the pump as indicated in the following section and emptying the reservoir of oil.*

#### 4.4 Storage

Empty the pump of any oil or grease and close the intake and outlet with the specific protection. The pumps must be stored in their own packaging and kept in covered, dry, protected places that are not exposed to direct sunlight and at a temperature that falls within the range indicated on the technical specifications table.

#### 4.5 Environmental conditions

The pump must be installed and used in a covered and sufficiently lit facility. The installation area must possess all the requirements in terms of heights and air exchange, and it must comply with the requirements set by the relevant prevailing regulation.

##### Temperature

The required work environment temperature values are indicated on the technical specifications table.

##### Lighting

All the areas must be lit in a uniform way and sufficiently to guarantee all the operations foreseen in the manual, preventing areas of shade, reflections, glaring or fatiguing for the vision.

#### 4.6 Installation

 No pump installation operations are required. The pump is secured to a metallic pallet which allows safe handling with a pallet jack or a forklift. The pallet itself is designed to be able to be installed in the system since it is equipped with 4 Ø14 mm holes suitable for floor-mounting. Provide adequate spaces (as per the installation diagram) to prevent abnormal posture or the possibility of impact. Subsequently, as previously described, the pump's hydraulic connection to the machine must be made, followed by the connection to the control panel.



##### **DANGER**

*The pump connections must be made only by qualified and specifically trained personnel.*

## 4.7 Electrical connection



### DANGER

*The connection to the ground must be made only by an electrical maintenance technician.*

The pump must be installed in an industrial environment in compliance with prevailing law.

In order to prevent dangers of electrocution due to direct or indirect contact with the live parts, the electrical power supply line must be adequately protected with a specific breaker switch with 0.03 Ampere tripping threshold and max tripping time of 1 second.



### ATTENTION

*Adhere to the indications on the EC identification label.*

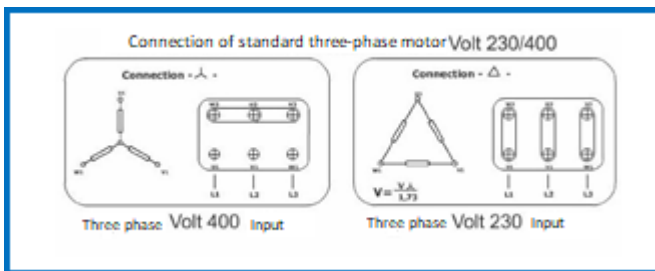

FLOW	110 cc/min
VOLT	230/400V 50Hz
PRESSURE	380 bar Max
TANK	30 Kg Max
GREASE	MAX NLGI 2



### ATTENTION

*A disconnect switch must be installed on the machine that hosts the pump.*



### ATTENTION

*The switch's disconnect power must be  $\leq 10$  kA and the rated current  $I_n = 6$  A.*



### ATTENTION

*All the electrical components must be connected to the ground. This is valid both for the electrical components and for controller devices. For this purpose, ensure that the ground wire is connected directly. For safety reasons, the ground cable must be about 100 mm longer than the phase wires. In the event of accidental disconnection of the cable, the ground terminal must be the last to disconnect.*

## 5. Operating instructions



### ATTENTION

*Use gloves and eye protection as required by the oil or grease lubricant safety data sheet.*



### DANGER

*Never ignore health hazards and always follow sanitary regulations.*

Before using the MINISUMO II pump, some preliminary checks must be carried out:

- Check the integrity of the pump.
- Ensure that the pump is at operating temperature and that the piping is free of any air bubbles.
- Ensure that the electrical connection has been carried out correctly.
- With the pump started, ensure that the electric motor rotation direction matches the arrow on the motor's protective casing. If it turns in the opposite direction, reconnect as indicated on the electrical diagram attached to the motor.
- The unit can be opened and repaired only by specialized personnel.

### 5.1 Preliminary procedures

#### 5.1.1 Filling the reservoir with grease

To fill the pump reservoir with grease, proceed as follows:

- 1) Unscrew the cap using an appropriate wrench;
- 2) Using the ½" fitting, introduce grease into the reservoir.  
The reservoir must be filled until reaching the maximum level. This level is signalled by the rising of the level rod or, if present, by the laser level probe (optional).
- 3) Screw the cap back on.

### 5.2

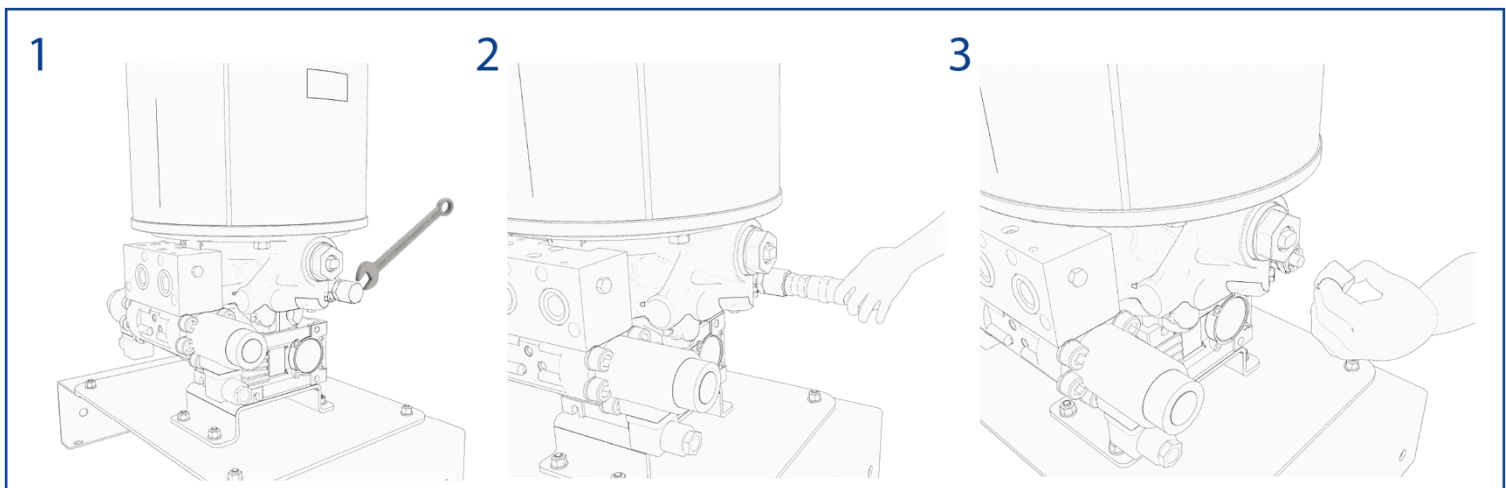



### 5.3 Starting the pump

1. Press the start button on the machine or system where the pump is connected.
2. Ensure that the pump starts; rotation of the motor, dispensing of the grease and pressurised piping indicate that the pump is actually working.
3. To change the pressure valve, act on the by-pass valve adjustment screw (see Sect. 3.5). Turn clockwise to increase or anticlockwise to decrease the pressure (see adjacent figure);

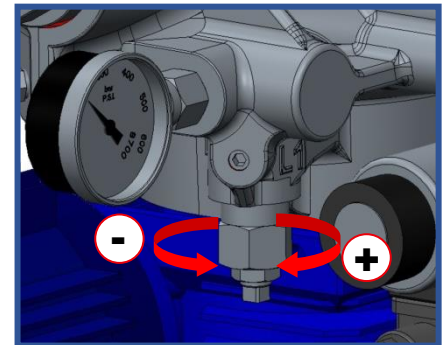

The pump is intended to feed two lines.

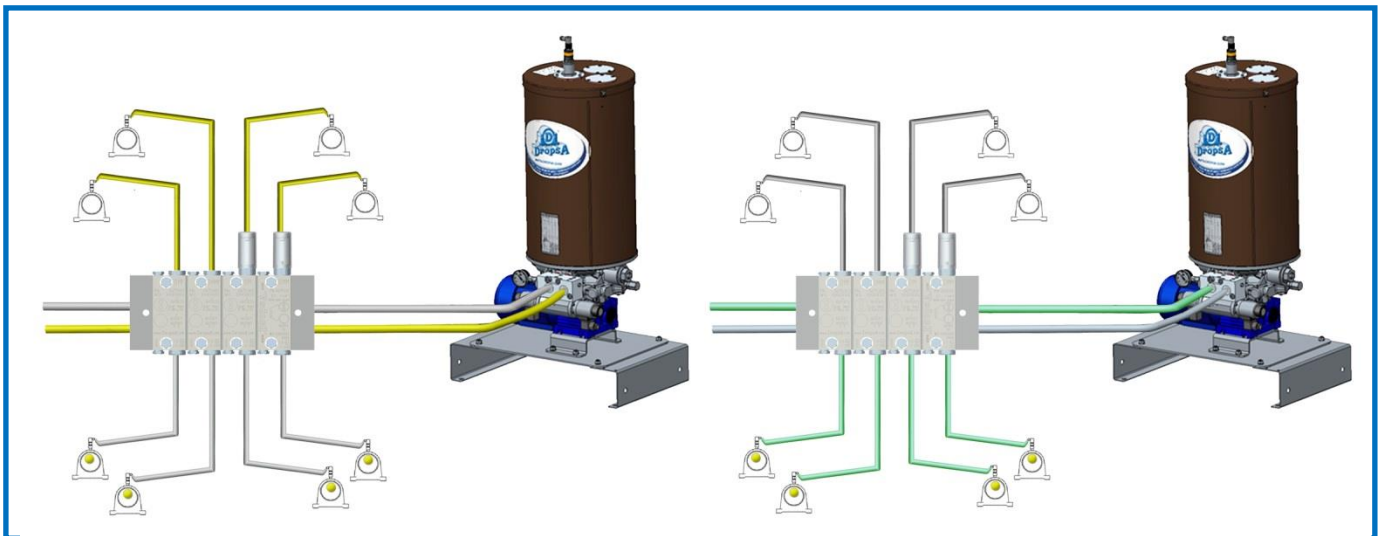

See sections 3.3 and 3.4 for the pump technical data.

### 5.4 Stopping the pump

Stopping the pump depends directly on the system where it is installed.

## 6. Adjustments

### 6.1 Adjustment/calibration of the level probe

#### 6.1.1 Calibration of the laser Level probe 0295131, 24Vdc Out NO and NC (1 threshold)

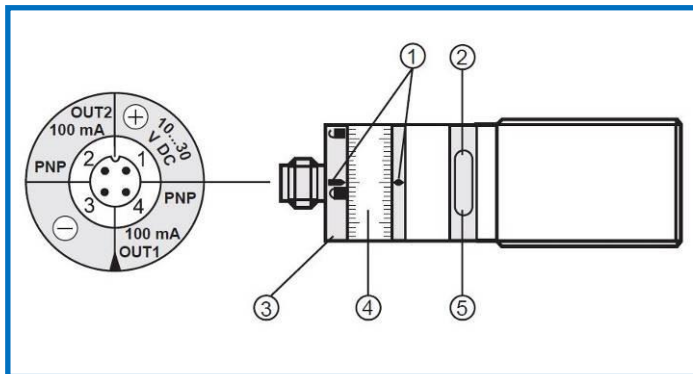

1. Reference notch.
2. Yellow LED: lights when the set value is reached (outlet=ON).
3. Locking ring nut.
4. Setting ring nut (manually adjustable after unlocking).
5. Green LED: indicates the correct power supply (24Vdc).

To obtain a correct setting, take the setting ring nut to the maximum value and then descend to the desired value.

A label is positioned on the pump with the electrical connection diagram and the settable threshold values. The pump is normally supplied with the sensor preset at the threshold "L" (minimum level).

Whereas the other thresholds:

- MM (absolute maximum level);
- M (maximum level);
- LL (absolute minimum level);

can be set by the user.



#### ATTENTION

Only one threshold at a time can be set.

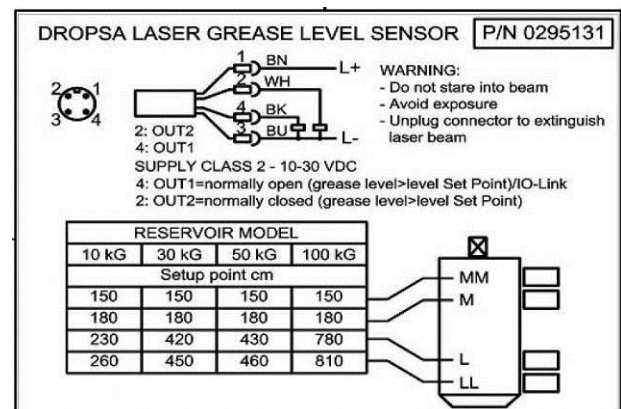

### 6.1.2 Laser probe calibration thresholds 0295130, 24Vdc Out 4~20mA/2 NO (4 thresholds)



The laser probe has a display for viewing and programming mounted on board. You can work in analogue (with signal from 4 to 20 mA) or digital (two outputs and four intervention thresholds).

Attached is a table with the laser probe calibration parameters.

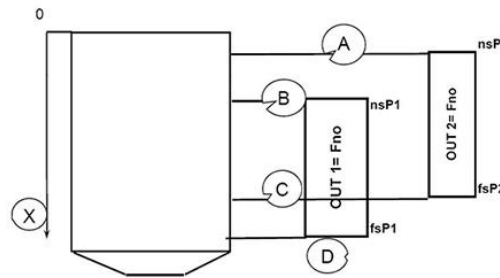

LASER PROBE CALIBRATION									
Pos.	Level	Signal Outlet	set-up	10 Kg reservoir		30 Kg reservoir		100Kg reservoir	
				quot a X [mm ]	grease quantity [Kg]	quota X [mm]	grease quantity [Kg]	quota X (mm)	grease quantity (Kg)
A	Absolute maximum level	OUT 2= Fno	nsP2	220	11	220	23	220	90
C	Minimum level		fsP2	300	5	490	5	850	17
B	Maximum Level	OUT 1= Fno	nsP1	250	9	250	21	250	86
D	Absolute minimum level		fsP1	330	3	520	3	880	14



**NOTE:** To vary the laser probe calibration thresholds, contact DropsA personnel.

### 6.1.3 REED floating switch connection 0295150/0295160

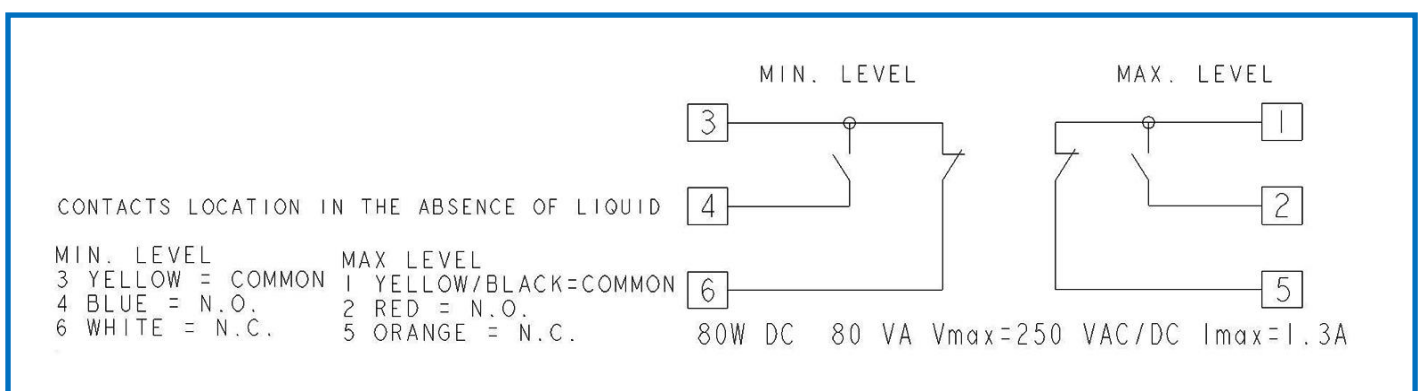

## 7. Maintenance

### 7.1 General warnings



#### DANGER

Ensure that the electrical power supply and the hydraulic power of the system where the pump is installed are disconnected before carrying out any maintenance operations.



#### DANGER

Do not carry out any type of operation, change and/or repair of any kind, except those indicated in this manual.

Only



trained or authorised technical personnel possess the necessary experience for carrying out any operation with the appropriate technique.



#### DANGER

Should maintenance on the pump be carried out in a way that does not comply with the instructions provided, with non-original replacement parts or without written authorisation from the manufacturer, or in any case in such a way so as to compromise the integrity or modify the characteristics, DropsA S.p.A. will not be held liable for personnel safety and the defective operation of the pump.



#### DANGER

Do not remove or tamper with the warranty seal for any reason whatsoever.



The pump has been designed and built in a way to require minimum maintenance.

In order to simplify maintenance, we recommend installing it in a position that is easy to reach.

The machine does not require special tools for any check and/or maintenance operations.



It is recommended to use suitable equipment and personal protective equipment (gloves and eye protection) that are in good condition in accordance with applicable regulations to avoid damage to people or parts of the machine.

For good maintenance, the following is important:

- immediately check the causes of any faults (excessive noise, overheating, etc.),
- pay particular attention to the safety devices,
- use all the documentation provided by the manufacturer (operating manual, electrical diagrams, etc.),
- use only tools suitable for the job and original replacement parts.

In the event of doubts and/or irresolvable problems, do not search for the fault by disassembling parts of the machine, but rather contact the DropsA S.p.A. Technical Office.





## 7.2 Maintenance operations table



### DANGER

**To carry out all maintenance operations, wear adequate personal protective equipment, namely gloves and eye protection, and ensure that there are no other operators in the vicinity.**

The following table shows all the periodic operations required to maintain the pump in perfect operating condition.

TYPE OF OPERATION	FREQUENCY INTERVAL	OPERATOR QUALIFICATION
Piping joints check	periodic	
General cleaning of the pump	periodic	
Cleaning the filling filter	2,000 h	
Replacing pumping elements	As needed	

### 7.2.1 Piping joints check

Periodically check the joints of the lines for any leaks.

### 7.2.2 General cleaning of the pump

Always keep the pump clean in order to quickly detect any leaks or defects.

The pump must be cleaned to remove dirt deposits.

Proceed using a dry cloth.

**Take care not to damage the elements of the pump applying excess pressure with the cloth.**

Do not use liquids or substances other than those indicated.

## 7.2.4 Replacing pumping elements



### ATTENTION

*Before replacing the pumping element, empty the reservoir in order to avoid lubricant spills.*

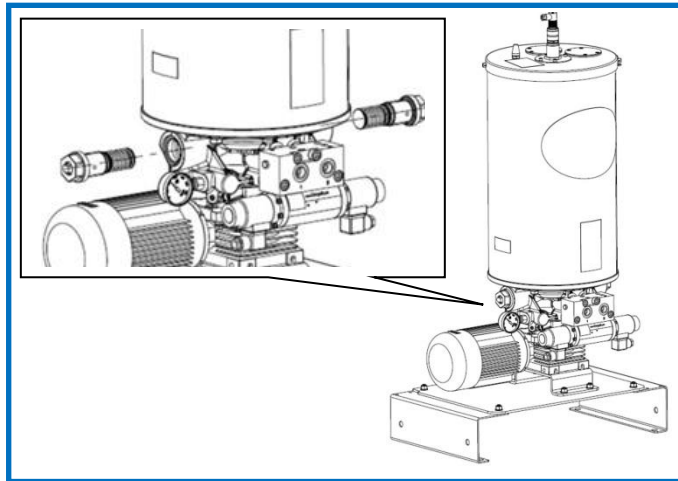

- 1) Using an appropriate wrench, remove the pumping element being replaced;
- 2) Replace the pumping element;
- 3) Tighten to a torque of 200 Nm.

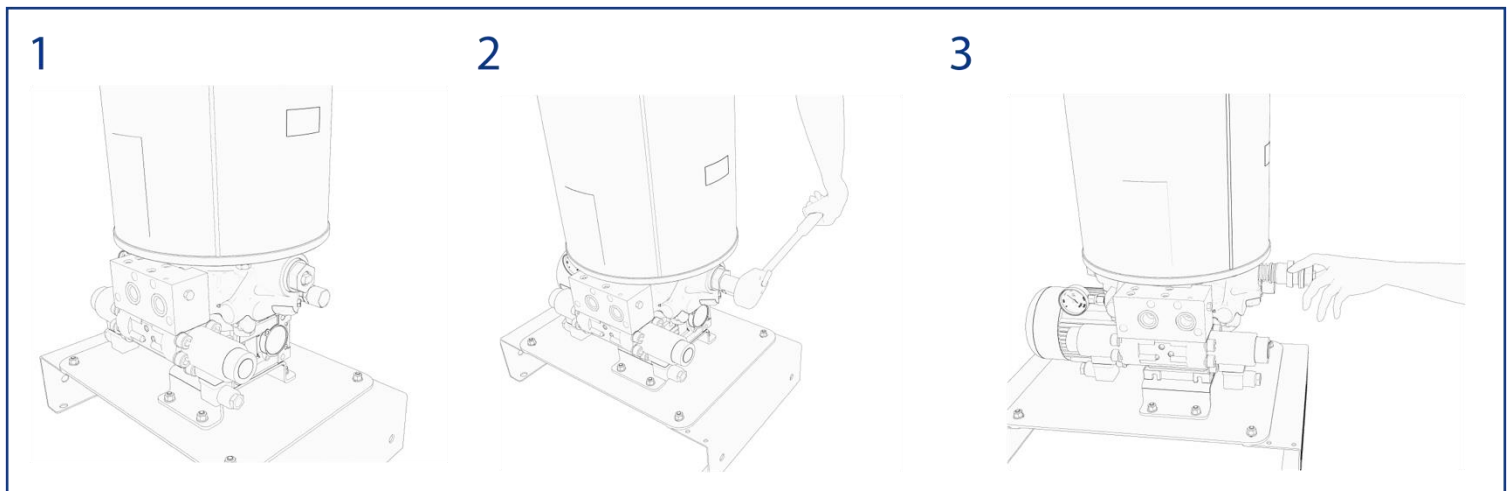

## 8. Troubleshooting

### 8.1 Problems, causes and solutions



#### ATTENTION

*The machine can be opened and repaired only by authorised DropsA personnel.*



#### DANGER

*To carry out all the indicated operations, wear adequate personal protective equipment.*

Below is a troubleshooting table highlighting the main failures, probable causes and possible solutions. If, after having consulted the diagnostics table, you are unable to solve the problem, do not search the failure by removing parts of the machine. Please contact the DropsA Technical Department and report the detected failures, with a detailed description.

Fault	Cause	Solution
The electric pump does not dispense lubricant.	<p>The electric motor does not work.</p> <p>The reservoir is empty.</p> <p>The pump does not engage. Causes of the pump failing to engage:</p> <ul style="list-style-type: none"> <li>• The motor turns in reverse (clockwise);</li> <li>• The motor turns in the right direction, but the stirring paddle does not turn;</li> <li>• Air bubbles in the lubricant.</li> </ul> <p>The pressure regulation valve (bypass) has been calibrated to a value that is too low. Dirt in the check valve.</p>	<p>Check the connection between the motor and the electrical power supply.</p> <p>Check the motor windings.</p> <p>Check that the motor terminal strip connection plates are positioned in accordance with the power supply voltage.</p> <p>Fill the reservoir. Attention: if the reservoir has emptied without the minimum level electrical signal being sent, the minimum level contact must be checked.</p> <p>Remove the reservoir cover and check to ensure that the stirring paddle turns clockwise and moves the lubricant; otherwise, invert two of the three motor phases. See above.</p> <p>Disconnect the pump delivery pipe and bleed the lubricant until eliminating air bubbles.</p>
The pump does not pressurise.	Possible pumping element malfunction.	Replace the pumping element.
No minimum level signal when there is no lubricant in the reservoir.	Incorrect minimum level adjustment.	<p>Check for the correct operation of the level probe as follows:</p> <p>check for the correct adjustment of the laser level.</p>

## 9. Ordering information

### 9.1 Standard versions

Note: The pump's ordering part number is made up of 11 digits.

				<i>Standard</i>							
			Base data	4th	5°/6°	7th	-	8°	9°	10°	11°
<b>MINISUMO II PUMP</b>			<b>250</b>	<b>0</b>	<b>00</b>	<b>0</b>		<b>0</b>	<b>0</b>	<b>0</b>	<b>0</b>
	Description	DROPSA Code	PART NUMBER								
<b>Reservoir</b>	-	-	0								
	10kg	0297100	1								
	30kg	0295080	2								
	100kg	0295090	3								
<b>Three-phase electric motor</b>	Motor not present	-	00								
	STANDARD 230/400V 50Hz - 280/480V 60Hz	3301791	01								
			02								
			03								
	24V DC	3301518	10								
	Inverter not present	-	0								
<b>4/3 Electromagnetic valve</b>	24 V DC	0083550	1								
<b>4/2 Electromagnetic valve</b>	24 V DC	0083560	2								
<b>4/2 Electropneumatic inverter</b>	24 V DC	0083580	3								
<b>Hydraulic inverter</b>		0086450	4								
<b>Optional</b>											
<b>Minimum level</b>	The pump is supplied with 24Vdc Out NO and NC (1 threshold) standard laser level sensor		0295131	0							
	Laser 2 configurable digital outputs and 4~20mA		0295130	1							
	*Reed floating switch for oil 10kg		0295151+3130138	2							
	*Reed floating switch for oil 30kg		0295150+3130138	3							
	*Reed floating switch for oil 100kg		0295160+3130138	4							
<b>Maximum Level</b>	The pump is supplied with the standard floating switch visual level		0295100	0							
	Laser 24V cc Out NO and NC (1 threshold)		0295131 (for 10kg, 30kg and 100kg)	1							
<b>Heating jacket</b>	Heating jacket NOT PRESENT		-	0							
	pump heating jacket 10/30kg 110V-150W		0295066	1							
	Stainless steel pump heating jacket 10/30kg 230V-150W		0295103	2							
<b>Pumping elements</b>	the pump comes with a fixed flow rate pumping element		0298000	0							
	Two fixed flow rate pumping elements		0298000+0298000	1							

\* The floating switch levels for oil signal both the minimum and the maximum level.

For special executions, for example, version with separate outputs, contact our technical sales office.



## 9.2 Optional equipment

EQUIPMENT	DESCRIPTION	PART NUMBER
Oil conversion	Min/max oil level float kit 10 Kg (22lb)	0295151
	Min/max oil level float kit 30 Kg (66lb)	0295150
	Filling cap with filter	3130138
Terminal Box bracket	Bracket for installing a terminal wiring box onto the base pallet	3044455
Terminal	Terminal box	0291655
Electrical control box Bracket	Bracket for installing a terminal wiring box onto the base pallet	3044456

## 9.3 Spare parts

When replacing parts of the pump, always use **Original Spare Parts**.

When purchasing spare parts, always cite the model and serial number of the pump (you will find this information on the identification plate) as well as the part number of the replacement parts.

Spare Parts Description		Setting variation	Part number
Motors	3Ph - 0.37 Kw - 230Δ/400Y 50Hz 280Δ - ±5% 60Hz		3301791
	24V DC		3301518
Reducer			3301754
Maximum mechanical level kit 10~100 Kg (grease)			0295100
Laser probe assembly 10~100 Kg - 24Vdc Out NO and NC (1 threshold)			0295131
Laser probe assembly 24Vdc Out 4~20mA/2 NO (4 thresholds) - 10 kg		VAR 1	0295130
Laser probe assembly 24Vdc Out 4~20mA/2 NO (4 thresholds) - 30 kg		VAR 2	
Laser probe assembly 24Vdc Out 4~20mA/2 NO (4 thresholds) - 100 kg		VAR 3	
Filling filter			0297007
Stirring paddle filter			0297005
O-ring reservoir			3190485
By-pass valve			0234496
0 - 600 Bar pressure gauge			3292171
Pumping element			0298000C
Metallic pallet			0297023

*DropsA S.p.A.* will not be held liable for any worsening of the pump's performance or for damage caused by the pump due to the use of non-original replacement parts.

## 10. Additional information

During maintenance on the machine, or in the event of its demolition, do not dispose of contaminated parts into the environment. See local regulations for their correct disposal. Upon demolition of the machine, the identification label and any other document must be destroyed.

### 10.1 Waste disposal

Remember that the residues stemming from industrial processing which have not been declared similar to urban solid waste in quality or quantity should be considered special waste.

Deteriorated or obsolete machines are also special waste.

The user, in accordance with local legal regulations, must take particular precautions concerning the disposal of the materials, such as:

- Guards material (PVC and methacrylate)
- Pneumatic piping plastic
- Jacketed electrical cables
- Rubber belts
- Depleted oils

### 10.2 Toxic-harmful waste

All waste that contains or is contaminated by the substances indicated in the attachment to DPR 915/52 in implementation of directives 75/442 EC, 76/403/EC and 768/319/EC should be considered toxic-harmful waste.

Below are the main pictograms placed on the containers of hazardous or harmful material:



#### 10.2.1 Provisional storage

Provisional storage of toxic-harmful waste is permitted based on the foreseen disposal of the same via treatment and/or definitive storage.

**In any case, the prevailing laws in the user's country must be observed on the protection of the environment.**

#### 10.2.2 Characteristics of the containers

The fixed and mobile containers destined to contain toxic-harmful waste must possess suitable resistance requirements in relation to the chemical-physical properties and the hazardous characteristics of the contained waste.

The containers in which hazardous or harmful products or materials are stored must, for the purpose of making the nature of their content known, bear indications and markings.

### 10.2.3 Registration obligations

In accordance with the requirements of the Presidential Decree of 23 August 1982 concerning implementation of Directive 75/439/EC relative to the elimination of depleted oils, the loading/unloading logs must be kept by all the companies that produce special or toxic-harmful waste stemming from industrial and artisan processes.



***This requirement is valid in Italy. For other countries in the EEC area, please refer to national legislation.***



#### **DANGER**

*During disposal operations, there are risks of cutting, projection of fragments, entanglement, contact with moving parts and contact with chemical products. The operator in charge must use the appropriate personal protection equipment.*

### 10.3 Scrapping the machine



#### **ATTENTION**

*The dismantling and demolition operations must be performed by qualified personnel.*

Dismantling of the machine must take place after the disassembly of the various parts that make it up. For the disassembly operations, in addition to wearing the Personal Protection Equipment mentioned in the MANUAL, please refer to the instructions and diagrams in this manual or, if necessary, request specific information from the Manufacturer.

Once the various parts have been disassembled, the various components will be subdivided, separating the metal from the plastic, the copper, etc., depending on the prevailing type of sorted disposal in the country where the machine is dismantled.

The waste stemming from the demolition of the machine can be classified as special waste.

In the event that the various components must be stored while awaiting disposal, take care to store them in a safe place that is protected from atmospheric agents in order to prevent the possibility of soil and groundwater contamination.

### 10.4 Dismantling of the electronic components (WEEE directive)



European Community directive 2002/96/EC (WEEE) imposes a series of obligations on the manufacturers and users concerning the collection, treatment, recovery and disposal of this waste.

Always strictly adhere to these regulations for the disposal of this waste. Remember that incorrect disposal of this waste implies the application of the administrative sanctions envisaged by the prevailing regulation.

## 11 Attachments

### 11.1 Hydraulic diagrams

Below are the hydraulics diagrams related to the various configurations that can be obtained with the available accessories.

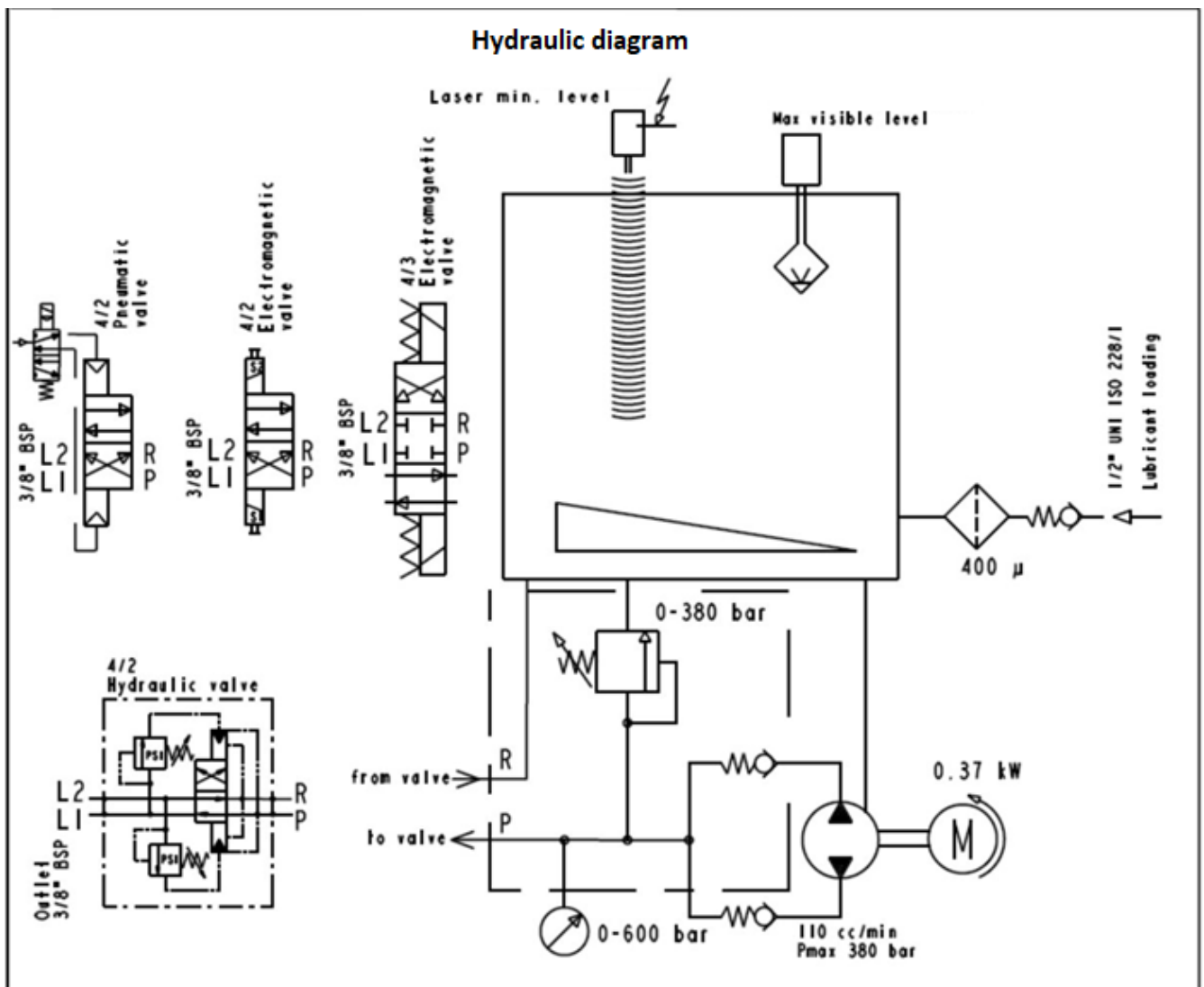

# DropsA

Lubrication Systems Specialists

## **DropsA S.p.A.**

Via Benedetto Croce,1  
20090 Vimodrone (MI)  
Tel: +39 02 250 79 1  
Fax: +39 02 250 79 767  
[www.dropsa.com](http://www.dropsa.com)

## **Copyright**

© 2020 DropsA S.p.A. Via Benedetto Croce,1- 20090 Vimodrone (MI)

This documentation is protected by copyright.

All rights reserved, including translation.

All rights reserved for the case of granting of patent or registration of utility model.

No part of this document may be reproduced in any form (e.g. printed matter, copying, microfilm or any other method) or processed, duplicated or distributed in data-processing systems.

Contraventions shall be liable for damages. Reprints, even of extracts, are only permitted with the approval of DropsA S.p.A.

We reserve the right to implement technical modifications to the machine at any time in order to improve safety, reliability, function and design.

All descriptions and information in this product catalogue apply to the current state at the time it was created.

We reserve the right to change the contents of this document without notice.

We point out that the software and hardware designations used in this document and the trade names of the individual firms are subject to general protection under the law of trademarks or patent law.

The textual and drawing representation may not necessarily comply with the scope of delivery.

The technical drawings may not necessarily be drawn to scale.