



CHARACTERISTICS

- **Delivery:**
0.03-0.16/0.20-0.50/0.75-1.00

- **Minimum pressure:**
bar 12(175)

- **Maximum pressure:**
bar 50 (725)

- **Maximum pressure of release:**
bar 4 (58)

- **Lubricant:**
Oil 32-2000 cSt;
Grease NLGI 0

- **Minimum time of release (second):**
32s-250 cSt 10 260s-1000 cSt 200s NLGI 0 200

SYSTEM 33 VALVES WITH M10 THREAD

- New M10x1 thread positioned on the oil inlet side.
- Compatible with M10 manifolds.
- Cylindrical thread and copper gaskets (copper sealing ring).
- Can be designed directly into machine casting.
- High reliability. The 33V Injectors are fully assembled, tested and certified on a robotic system.



Operating characteristics:

		Delivery
		0,03 - 0,16 cm ³ /cycle (0,002 - 0,01 cu.in/cycle)
Minimum pressure bar (psi)		12 (175)
Maximum pressure bar (psi)		50 (725)
Maximum pressure of release bar (psi) **		4 (58)
Lubricant	Oil cSt (SUS)	32-2000 (150 – 9256)
	Grease	NLGI 0
Minimum time of release in second *	32-250 cSt (150 – 1157 SUS)	10s
	260-1000 cSt (1203 – 4628 SUS)	200s
	NLGI 0	200s

*Minimum time of release depending on the specifics of the systems where V33 injector are mounted. If they need to be assembled on medium or large – sized systems, please contact Dropsa’s technical – commercial department to check their real time of release

** Pressure at Injector Inlet

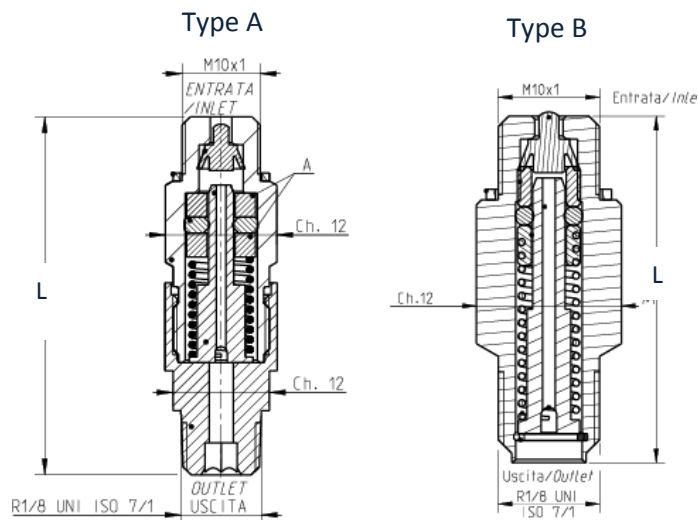

ORDER INFORMATION

Flow rate cc/stroke	Order number	Type	Length (L)
0.03	33VM003	B	~33,2
0.06	33VM006	B	~33,2
0.10	33VM010	B	~33,2
0.16	33VM016	B	~33,2
0.20	33VM020	A	45
0.30	33VM030	A	45
0.50	33VM050	A	45



MANIFOLDS

1 Description of application

The Bielomatik distributor strips are used for the installation of dosing elements, metering valves, compressor nozzles and as line branches in the single-line lubrication system.

2 Technical information

General	
Material and surface	Steel, surface galvanised
Operating pressure	100 bar

1 DIMENSIONS AND ORDER INFORMATION

Single sided

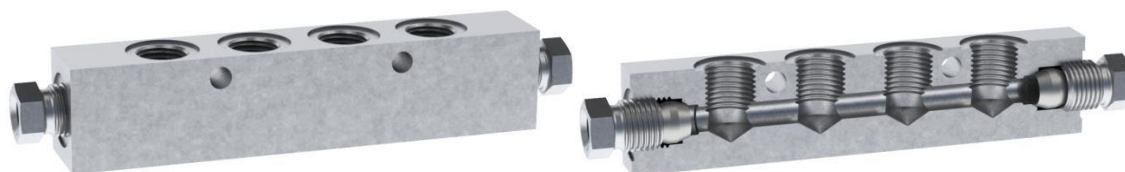

Number of outlets	Figure	Packaging unit [no.]	Dimensions			Order number
			a	L1	L2	
1	1	30	-	45	20	P30048201
2	2	20	-	57	32	P30048202
3	3	20	18	75	50	P30048203
4	3	20	36	93	68	P30048204
5	3	20	54	111	86	P30048205
6	3	10	72	129	104	P30048206
7	3	10	90	147	122	P30048207
8	3	10	108	165	140	P30048208
9	3	10	126	183	158	P30048209
10	3	10	144	201	176	P30048210
11	3	10	162	219	194	P30048211
12	3	10	180	237	212	P30048212

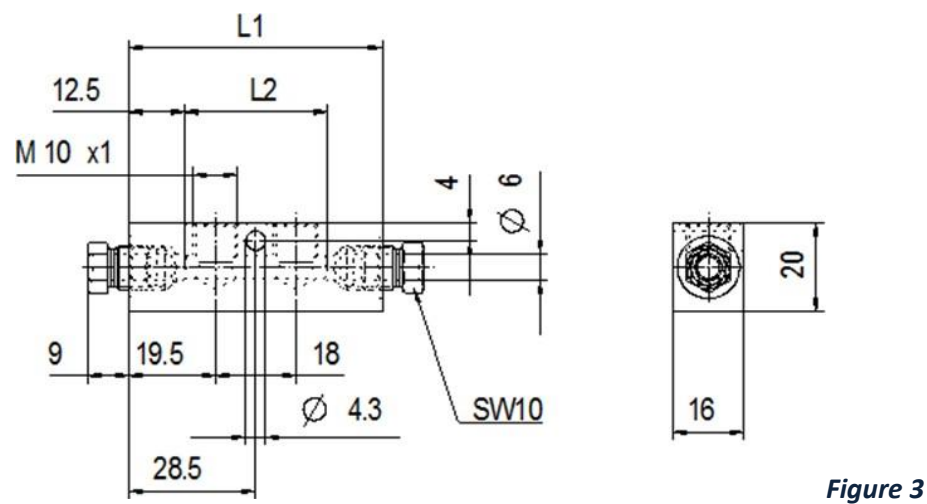
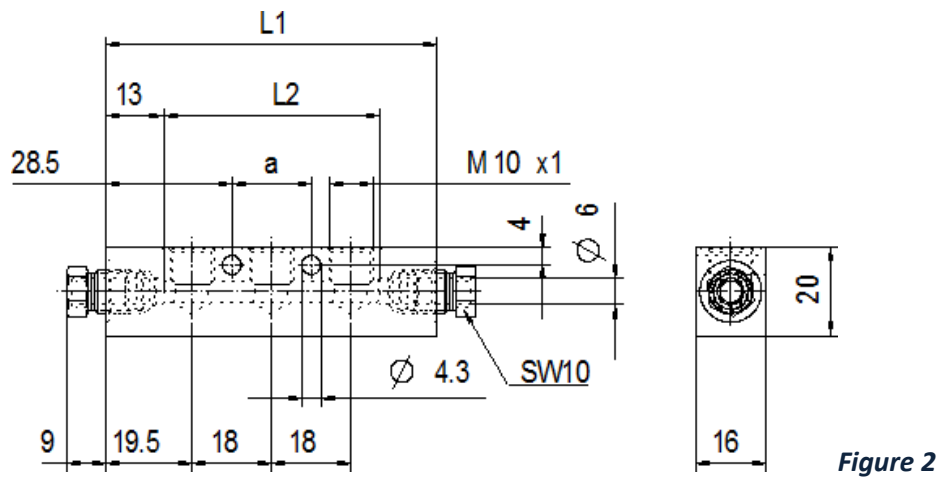
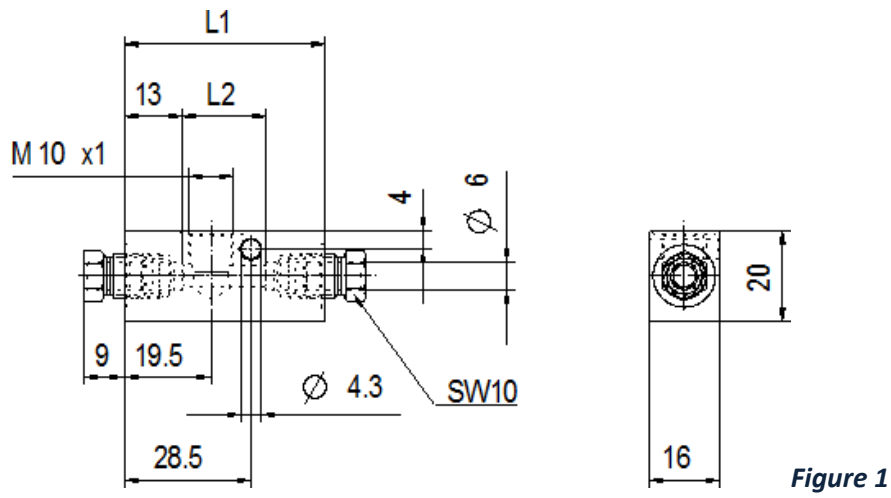



Double version

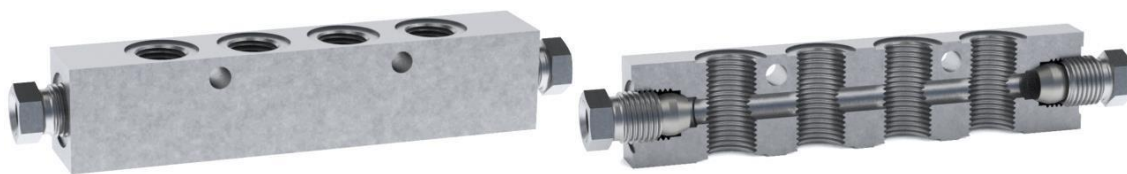

Number of outlets	Figure	Packaging unit [no.]	Dimensions			Order number
			a	L1	L2	
2x1	4	30	-	45	20	P30048001
2x2	5	20	-	57	32	P30048002
2x3	6	20	18	75	50	P30048003
2x4	6	20	36	93	68	P30048004
2x5	6	20	54	111	86	P30048005
2x6	6	10	72	129	104	P30048006
2x7	6	10	90	147	122	P30048007
2x8	6	10	108	165	140	P30048008
2x9	6	10	126	183	158	P30048009
2x10	6	10	144	201	176	P30048010
2x11	6	10	162	219	194	P30048011
2x12	6	10	180	237	212	P30048012

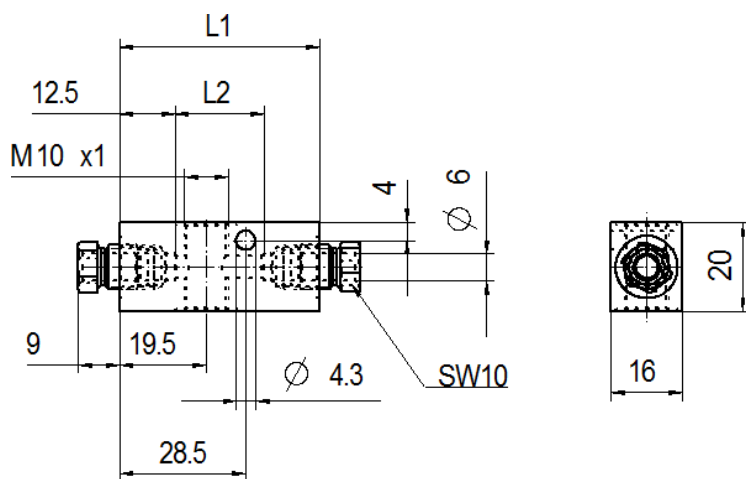

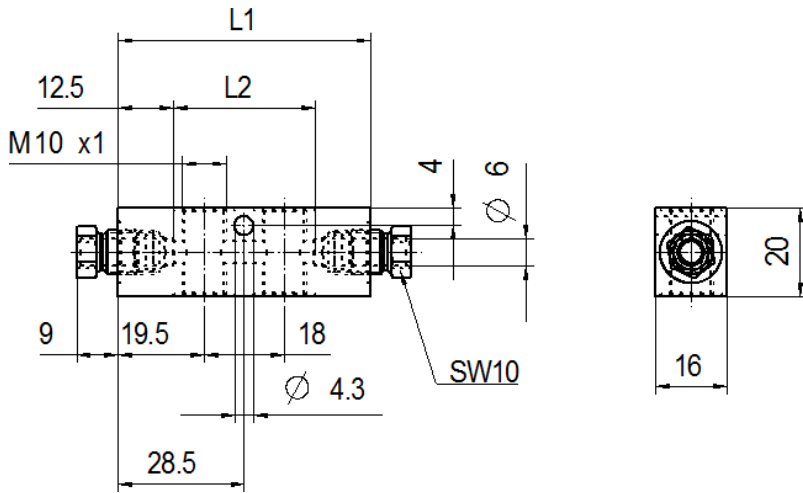

Figure 5

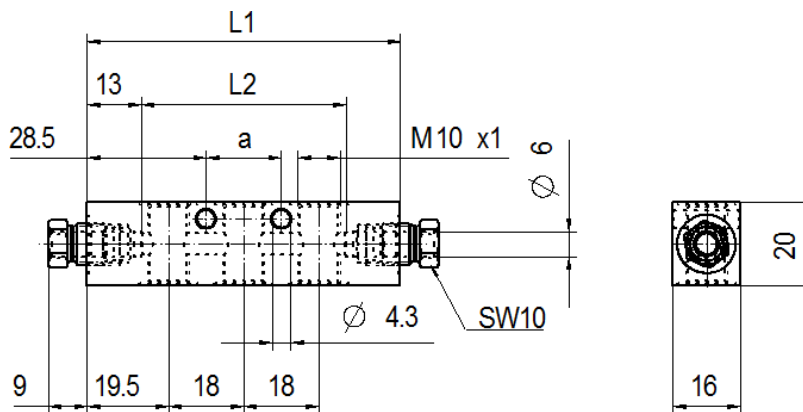
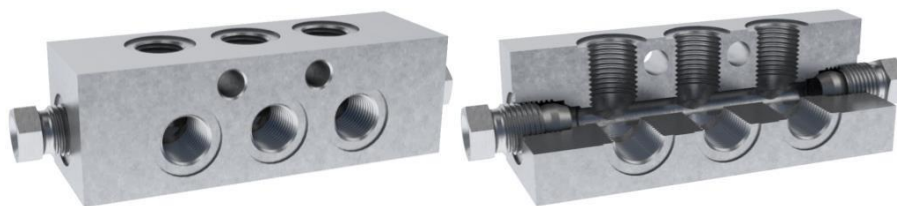

Figure 6

Angled version



Number of outlets	Figure	Packaging unit [no.]	Dimensions			Order number
			a	L1	L2	
2x1	7	15	-	40	215	P30048401
2x2	8	10	-	58	33	P30048402
2x3	9	10	18	76	51	P30048403
2x4	9	10	36	94	69	P30048404
2x5	9	10	54	112	87	P30048405
2x6	9	5	72	130	105	P30048406

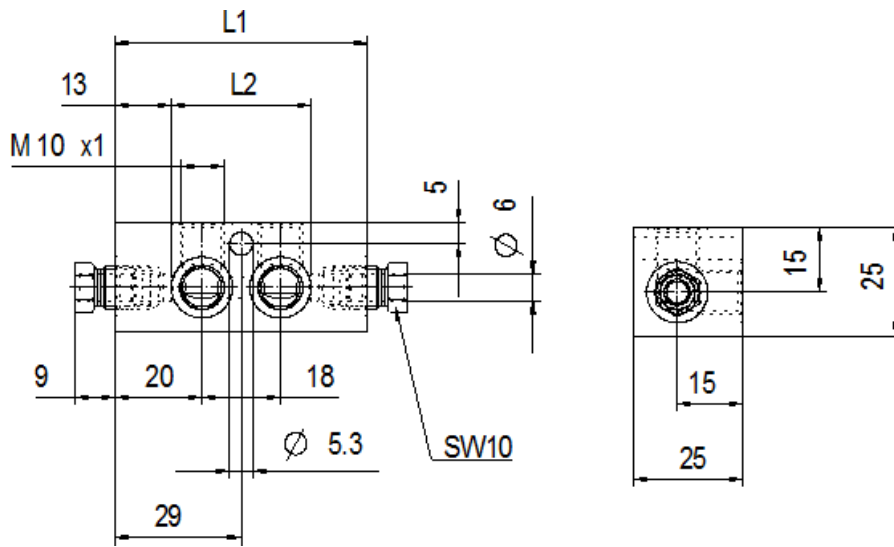

Figure 7

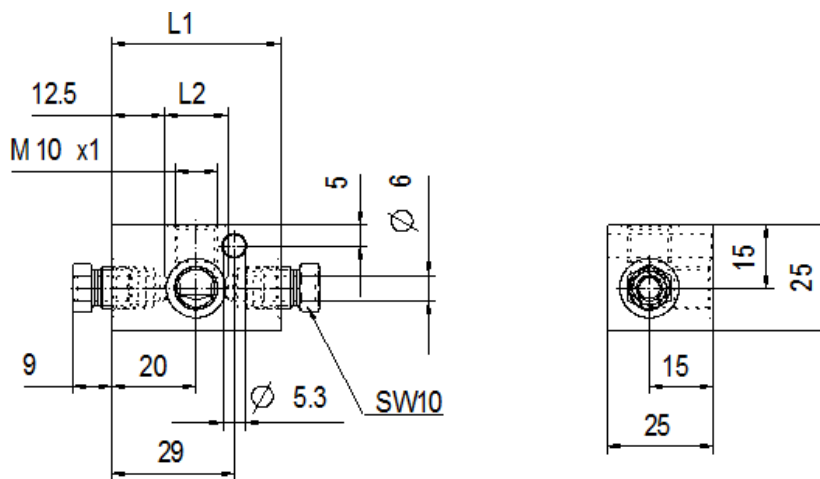

Figure 8

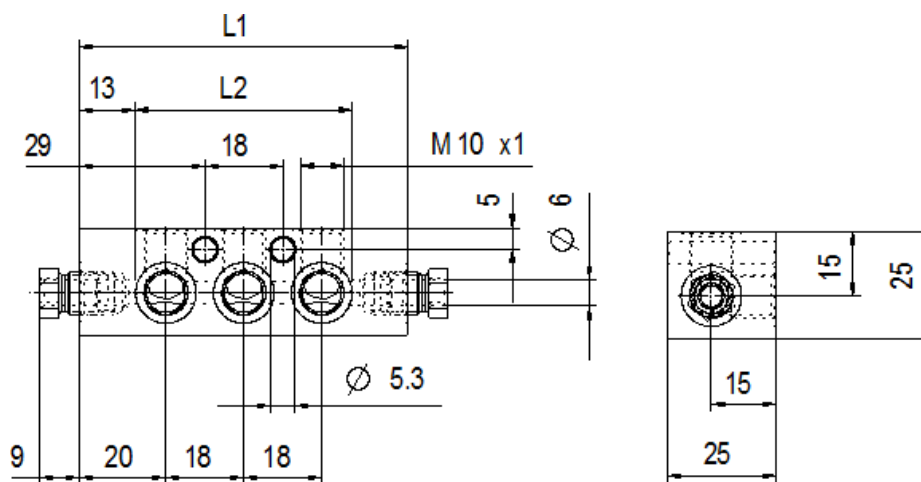

Figure 9



3 ACCESSORIES

Order number	Description
P30215201	Double conical ring
P30256619	Sleeve nut
P30047703	Tapping screw M4x25
P30047705	Tapping screw M4x35