



## CHARACTERISTICS

### Number of outlets:

- 6 to 50

### Dosing volume per outlet:

- 80 to 420 mm<sup>3</sup>

### Ambient temperature:

- From 32° to 212 °F

### Operating pressure:

- from 20 to 250 bar (from 290 to 3625 psi)

## Progressive distributor VE

Progressive distributor in disks, which is available with up to 50 lubrication outlets, each having a different dosing volume. The progressive distributor VE is suitable for distribution of challenging lubrication tasks with fluid grease or grease.

## TECHNICAL INFORMATION

### General

Type	Disc distributor
Lubrication line connection	G1/8
Ambient temperature	From 32 to 212 °F (from 0 to 110 °C)
Protection class as per EN60529	IP 67

### Hydraulic system

Operating pressure	From 20 to 250 bar (from 290 to 3625 psi)
Operating medium	Fluid grease, grease
Range of viscosity	NLGI 000-2

### Sensor system

<b>Circulation control</b>	
Switching voltage	24 V DC
Switching current	≤ 300 mA
Connection	M12 x 1

### Mode of operation:

When pressurized, the pistons in the divider move back and forth. The displaced lubricant flows towards the respective outlet. Shortly before the end position of the currently moving piston, the piston initiates the inflow and the outflow of the lubricant to the next piston via its control edge. Progressive distributors can pause in every position and restart. If an outlet is blocked, the progressive distributor blocks. This is a pre-requisite for simple monitoring of individual progressive distributors or those connected in series. There must be a circulation control in the system for monitoring that detects the monitoring time.

### Features:

All channels flow through completely with lubricant.

- No settling of the bled grease solids in the channels, which lead to blocking.
- self-venting

### Design:

Disk-type construction, with starter and end plate and optionally with 3 to 10 elements with / different dosing volumes. The disks are held together with 2 screws. Inlet through main line connection H in the starter plate. Through a dosing piston assembled in the lower part of the element, every element delivers 2 element-based dosed volumes, which can optionally be delivered laterally (L, R) or to the upper outlets (1, 2). The upper outlets are closed in the delivered condition. Opposite outlets can be connected. If connected the opposite outlets yield double the quantity (one outlet has to be closed). Adjacent outlets, outlets on the top or lateral outlets can be connected in pairs with bridges. A return valve is integrated in the progressive distributor per outlet. Backflow of grease is avoided. Electrical and optical circulation controls as well as pressure indicators are available in the kit.

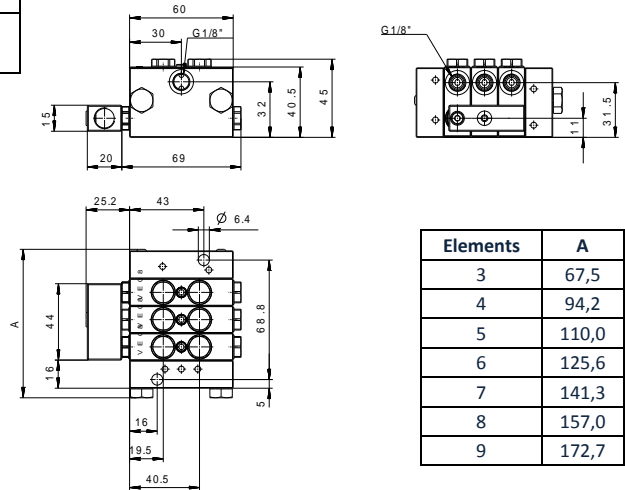

Elements	A
3	67,5
4	94,2
5	110,0
6	125,6
7	141,3
8	157,0
9	172,7

## IDEAL FOR

- Challenging lubrication tasks with fluid grease or grease

- Highly customized solutions

## APPLICATIONS

- General Machinery

- Progressive lubrication with fluid grease or grease

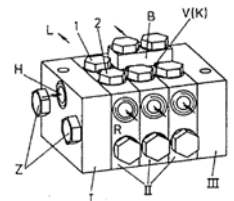



## ORDER NUMBER - CONFIGURATOR

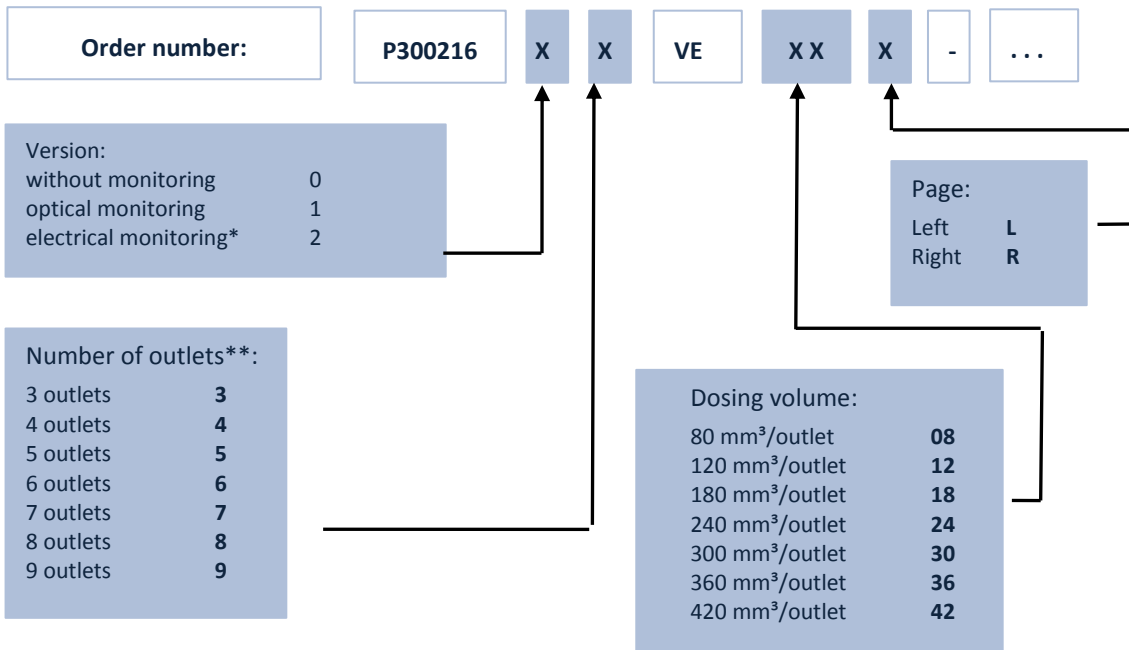

\* In progressive distributor with electrical circulation control the inductive proximity switch 676 62 047 must be ordered.

\*\* Up to 25 elements are available on request.

The dosing volume of the outlets must be named starting from input H. They must be specified with the code 08 for 80 mm<sup>3</sup> 42 for 420 mm<sup>3</sup> or similar.

If the dosing volume is combined by removing the ball and the plug screw on an opposite side, the outlet side must be mentioned. The side to be kept open should be specified through addition R or L as per the code. (R = Right; L = Left)

### Sample orders:

- Progressive distributor with 4 elements and 6 outlets.  
Progressivedistributor  
P30021604 VE 12R-08-18L-18
- Progressive distributor with 6 elements and 9 outlets and electrical circulation control.  
Progressive control with electrical circulation control  
P30021626 VE 18L-24-12R-30-30R-36

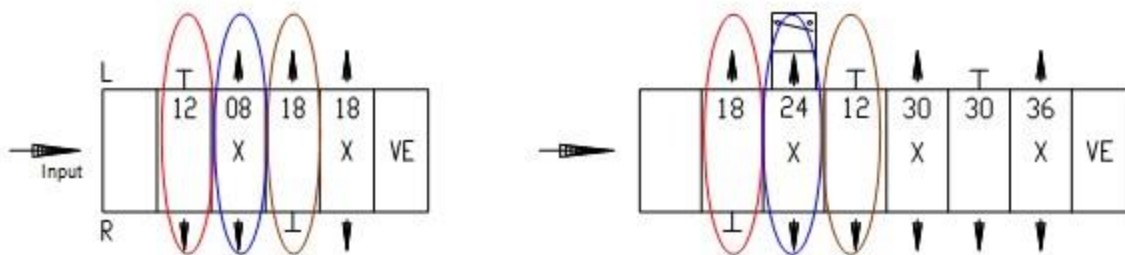



## ORDER OVERVIEW

Version		Order number	Version		Order number
Without Monitoring	3 Elements	<b>P30021603</b>	Optical Monitoring	7 Elements	<b>P30021617</b>
Without Monitoring	4 Elements	<b>P30021604</b>	Optical Monitoring	8 Elements	<b>P30021618</b>
Without Monitoring	5 Elements	<b>P30021605</b>	Optical Monitoring	9 Elements	<b>P30021619</b>
Without Monitoring	6 Elements	<b>P30021606</b>	Electrical Monitoring	3 Elements	<b>P30021623</b>
Without Monitoring	7 Elements	<b>P30021607</b>	Electrical Monitoring	4 Elements	<b>P30021624</b>
Without Monitoring	8 Elements	<b>P30021608</b>	Electrical Monitoring	5 Elements	<b>P30021625</b>
Without Monitoring	9 Elements	<b>P30021609</b>	Electrical Monitoring	6 Elements	<b>P30021626</b>
Optical Monitoring	3 Elements	<b>P30021613</b>	Electrical Monitoring	7 Elements	<b>P30021627</b>
Optical Monitoring	4 Elements	<b>P30021614</b>	Electrical Monitoring	8 Elements	<b>P30021628</b>
Optical Monitoring	5 Elements	<b>P30021615</b>	Electrical Monitoring	9 Elements	<b>P30021629</b>
Optical Monitoring	6 Elements	<b>P30021616</b>	Optical Monitoring	7 Elements	<b>P30021617</b>
Optical Monitoring	7 Elements	<b>P30021617</b>	Optical Monitoring	8 Elements	<b>P30021618</b>

**ACCESSORIES:** For main line connection H, outlets L, R, 1, 2 (see Fig.)

Designation	Dimensions [mm]					Drawing	Possible assembly	Order number
	d	1	S2	L	L1			
Straight pipe fitting	4	1	12	21	-	E4	L, R, 1, 2, H	<b>P30044152</b>
Straight pipe fitting	6	11	12	21	-	E6	L, R, 1, 2, H	<b>P30044147</b>
Straight pipe fitting	8	14	14	22	-	E8	L, R, 1, 2, H *	<b>P30043905</b>
Straight pipe fitting	10	17	19	29	-	E10	H	<b>P63812802</b>
Straight pipe fitting	12	19	22	49	-	E12	H	<b>P30044141</b>
Straight pipe fitting with return valve	6	17	14	41	-	R6	H	<b>P30022143</b>
Straight pipe fitting with return valve	8	17	17	39	-	R8	H	<b>P30022144</b>
Straight pipe fitting with return valve	10	17	17	41	-	R10	H	<b>P30022145</b>
Swivelling fitting	4	14	8	20	26	S4	L, R, 1, 2, H	<b>P30045523</b>
Swivelling fitting	6	14	10	20	29	S6	L, R, 1, 2, H	<b>P30045527</b>
Swivelling fitting	8	14	14	21	23	S8	H *	<b>P30045401</b>
Bridge	-	12	-	14	-	B	L, R, 1, 2	<b>P30045809</b>
Bridge with outlet	-	12	-	14	25	A	L, R, 1, 2	<b>P30045804</b>
Pressure indicator 100 bar	-	12	-	27	-	DZ 100	L, R, 1, 2, 3, 4	<b>P30027101</b>
Pressure indicator 50 bar	-	12	-	27	-	DZ 100	L, R, 1, 2, 3, 4	<b>P30027100</b>
Male fitting	6	0	-	5	-	D6	L, R	<b>P30256616</b>
Double taper ring	for Ø 6 mm pipe						L, R, 1, 2, H	<b>P30215201</b>

Fig.: Overview connections

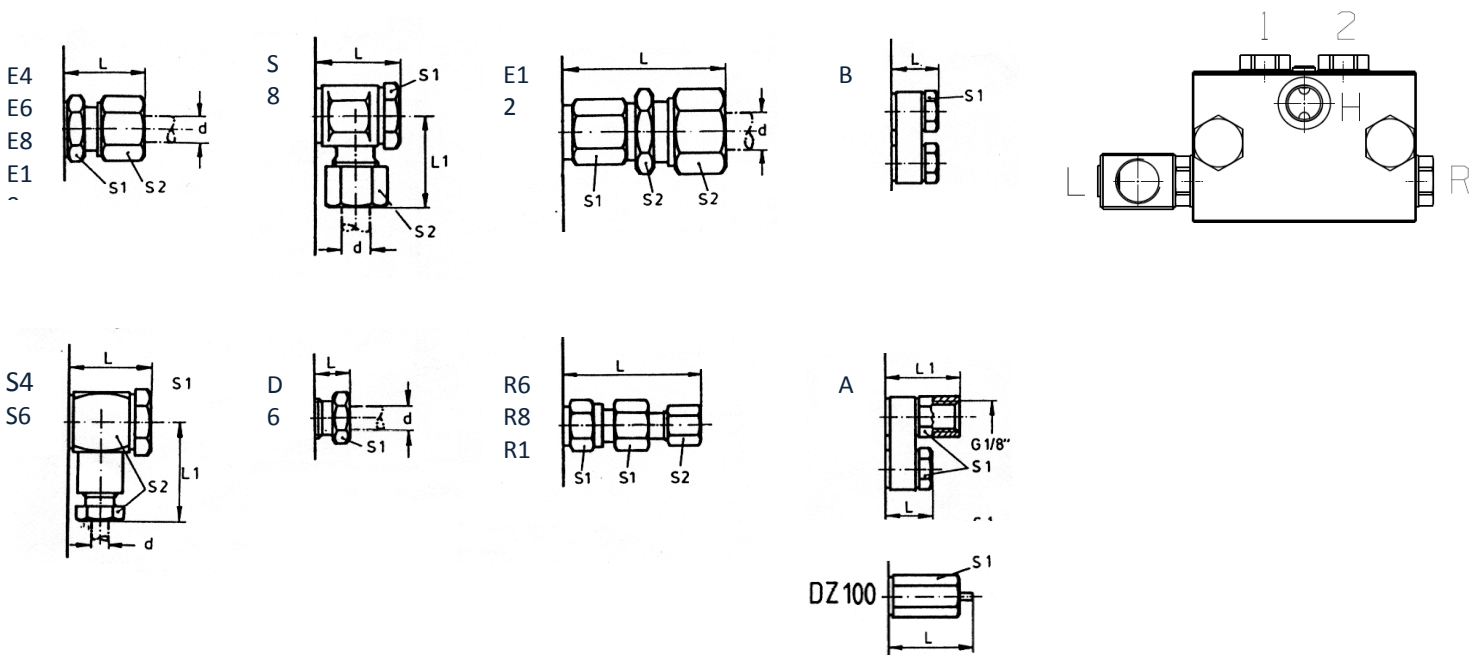



## PREFABRICATION - PROGRESSIVE LUBRICATION SYSTEM

As a special service Bielomatik offers system-wide prefabrication of the components. This service covers all imaginable assembly operations, which are possible before the delivery of the system.

- Filling the pump with the lubrication desired by the customer
- Filling the pipes and lines with the lubrication desired by the customer
- Lubrication system for complete installation in connection with a customer interface
- Customer-specific configuration of pumps (air or lubrication side with specific screw joints)
- Customer-specific modifications to standard elements
- Customer-specific packaging of fabricated systems
- Combinations of several systems

The advantage is that a complete system can be pre-fabricated ex-factory as per the customer's requirements thus significantly reducing the assembly time. Even placing the order is very simple as individual parts from all systems do not have to be ordered separately. You can get the delivery of a completely pre-fabricated lubrication system under one order number.

The following examples show only a small extract from the various options of pre-fabrication from Bielomatik Schmiertechnik GmbH. Please contact our sales team for your individual quotation.

### Example 1:

The figure shows a progressive distributor VE with 3 elements with the assembly **VE 42-36-42**. The distributor is provided with customer-specific various screw joints and equipped with additional pressure indicators.

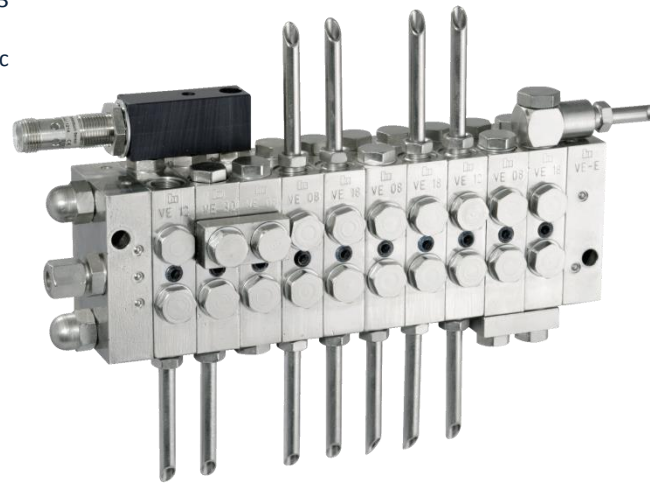
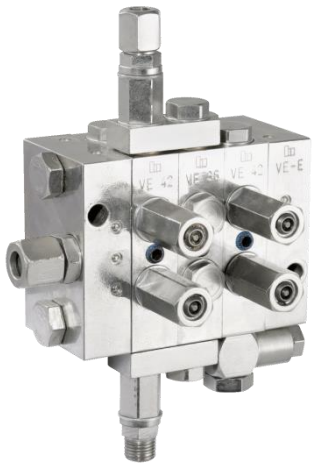

### Example 3:

The figure shows a customer-specific lubrication cabinet with electronic control for automated lubrication of up to 8 lubrication circuits. The lubrication cabinet comprises a pump for 50 kg keg, level and function monitoring and an outlet stop.



### Example 2:

The figure shows a progressive distributor VE with 8 elements with the assembly **VE 12-30-08-08-18-12-08-18**. The distributor is provided with customer-specific various screw joints and has an additional electronic circulation control.